



PDF700S CMFC(D/D-P), PDF700B CMFD(D-P) Series
Application Note October V12

**AC-DC Switching Power CHASSIS MOUNT
PDF700S CMFC(D/D-P),
PDF700B CMFD(D-P) SERIES
APPLICATION NOTE**



Approved By:

Department	Approved By	Checked By	Written By
Research and Development Department	Ovid	Wei-Cheng	SYLin
Design Quality Department	Benny	JoJo	



PDF700S CMFC(D/D-P), PDF700B CMFD(D-P) Series Application Note October V12

Contents

1. Introduction	3
2. Pin Function Description	4
3. Electrical Diagram	8
4. Terminal Block	9
5. Connection for Standard Use	10
6. Test Set-Up	10
7. Features and Functions	10
7.1 Over Current Protection	10
7.2 Over Voltage Protection	10
7.3 Over Temperature Protection	10
7.4 Remote On/Off	11
7.5 Output Remote Sensing	11
7.6 Output Voltage Adjustment	12
7.7 IOG Signal	13
8. Input/Output Considerations	14
8.1 Hold Up Time	14
8.2 Inrush Current Limiting Resistor TRF1	14
8.3 Derating Curve	14
8.4 Output Ripple and Noise	14
8.5 Series Operation	15
8.6 Parallel Operation	16
8.7 EMC Considerations	18
9. Thermal Design	26
9.1 Operating Temperature Range	26
9.2 Convection Cooling Requirements	26
9.3 Thermal Considerations	26
9.4 Power Derating	27
10. Packing Information	28



PDF700S CMFC(D/D-P), PDF700B CMFD(D-P) Series Application Note October V12

1. Introduction

The PDF700S-CMFC(D) and PDF700B-CMFD series of AC-DC converters provide 700 watts of output power at single output voltages of 12, 24, 28, 48, 56Vdc. High efficiency up to 91.5%, allows for case operating temperatures from -40°C to 95°C. An optional heat sink can be used to extend the full power range of the unit, and the heat sink can refer to the power derating curve in the specification sheet. In addition, the PDF700S(B)-CMFD-P series is a product specifically designed for parallel operation using the voltage droop method and no share bus. See **section 8.6** for parallel operation.

Standard control functions include remote on/off and +5%, -5% (PDF700S560-CMFC(D) and PDF700B560-CMFD +1.8%, -5%) adjustable output voltage. The output voltage can be adjusted in **section 7.6**.

If parallel operation is required, it is recommended to use the CMFD series with the CSC01 module or only the CMFD-P series, while the CMFC series cannot be operated in parallel. For operation, please refer to the CSC01 or CMFD-P application note separately.

Fully protected against input under-voltage-lock-out (UVLO), output over-current, output over-voltage, over-temperature and continuous short circuit conditions.

PDF700 Family as Flow:

	EMI (EN 55032)	Parallel	MIL-STD-461	Aluminum Cover
PDF700S-CMFC	Class A	No	CE102/RE101	No
PDF700S-CMFD	Class A	No	CE102/RE101	Yes
PDF700S-CMFD-P	Class A	Yes	CE102/RE101	Yes
PDF700B-CMFD	Class B	No	CE101(Submarine) /CE102/RE101	Yes
PDF700B-CMFD-P	Class B	Yes	CE101(Submarine) /CE102/RE101	Yes



PDF700S CMFC(D/D-P), PDF700B CMFD(D-P) Series Application Note October V12

2. Pin Function Description

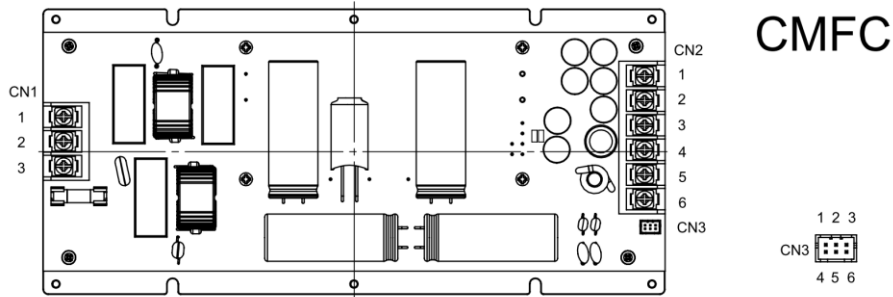

No	CN1	Function	Description
1	FG	Connected to Baseplate	Connected to Baseplate (FG)
2	AC1	AC Input	AC Supply Input
3	AC2	AC Input	
--	--	Mounting Insert	Mounting Insert (FG)

No	CN2	Function	Description
1-3	-Vo	-V Output	Negative Power Output
4-6	+Vo	+V Output	Positive Power Output

No	CN3	Function	Description
1	ON/OFF+	Remote On/Off+	Connect Current Source Between On/Off+ and On/Off- to Remote On/Off the module
2	I/OG	Monitor Operating Signal	Monitor Normal and Abnormal Operation of The Converter
3	NC		NC
4	ON/OFF-	Remote On/Off -	Connect Current Source Between On/Off+ and On/Off- to Remote On/Off The Module
5	NC		NC
6	NC		NC

Note:

1. Baseplate can be connected to FG through M4 mounting insert. Recommended torque 9.6~12.8Kgf-cm.
2. When remote sense function (+S/-S) is used, it is recommended to use CMFD series instead of CMFC series. The output voltage of CMFC series can only be adjusted by R12/R13 in **section 7.6**.



PDF700S CMFC(D/D-P), PDF700B CMFD(D-P) Series Application Note October V12

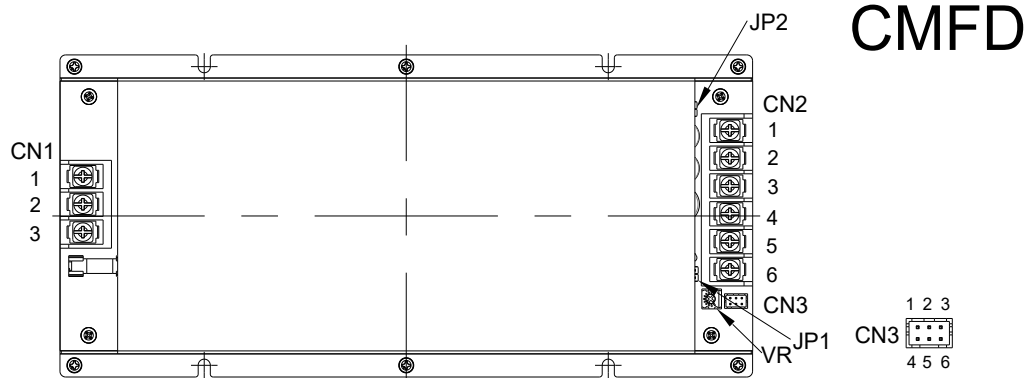

No	CN1	Function	Description
1	FG	Connected to Baseplate	Connected to baseplate (FG)
2	AC1	AC Input	AC Supply Input
3	AC2	AC Input	
--	--	Mounting Insert	Mounting Insert (FG)

No	CN2	Function	Description
1-3	-Vo	-V Output	Negative Power Output
4-6	+Vo	+V Output	Positive Power Output

No	CN3	Function	Description
1	TRIM	Trim	External Output Voltage Adjustment for Only CMFD
2	-S	-Sense	Negative Output Remote Sense for Only CMFD
3	ON/OFF-	Remote On/Off -	Connect Current Source Between On/Off+ and On/Off- to Remote On/Off The Module
4	IOG	Monitor Operating Signal	Monitor Normal And Abnormal Operation of The Converter
5	+S	+Sense	Positive Output Remote Sense for Only CMFD
6	ON/OFF+	Remote On/Off+	Connect Current Source Between On/Off+ and On/Off- to Remote On/Off The Module

No	Label	Function	Description
1	JP1	Jumper	Short +S & +Vo for Only CMFD
2	JP2	Jumper	Short -S & -Vo for Only CMFD
3	VR	Vo ADJ.	Internal Output Voltage Adjustment by Variable Resistor (VR) for Only CMFD

Note:

1. The CMFD means PDF700S-CMFD series.
2. Baseplate can be connected to FG through M4 mounting insert. Recommended torque 9.6~12.8Kgf-cm.
3. The output voltage of CMFD series can be adjusted by VR (Vo ADJ.) or R12/R13 in **section 7.6**.



PDF700S CMFC(D/D-P), PDF700B CMFD(D-P) Series Application Note October V12

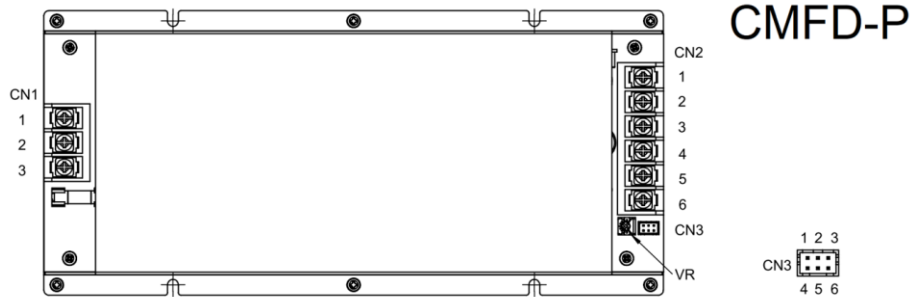

No	CN1	Function	Description
1	FG	Connected to Baseplate	Connected to baseplate (FG)
2	AC1	AC Input	AC Supply Input
3	AC2	AC Input	
--	--	Mounting Insert	Mounting Insert (FG)

No	CN2	Function	Description
1-3	-Vo	-V Output	Negative Power Output
4-6	+Vo	+V Output	Positive Power Output

No	CN3	Function	Description
1	-Vo	-V Output	Negative Power Output
2	NC		NC
3	ON/OFF-	Remote On/Off -	Connect Current Source Between On/Off+ and On/Off- to Remote On/Off The Module
4	IOG	Monitor Operating Signal	Monitor Normal and Abnormal Operation of The Converter
5	NC		NC
6	ON/OFF+	Remote On/Off +	Connect Current Source Between On/Off+ and On/Off- to Remote On/Off The Module

No	Label	Function	Description
1	VR	V _o ADJ.	Internal Output Voltage Adjustment by Variable Resistor (VR)

Note:

1. The CMFD-P means PDF700S-CMFD-P series.
2. Baseplate can be connected to FG using M4 mounting insert. Recommended torque 9.6~12.8Kgf-cm.
3. The output voltage of the CMFD-P series can be adjusted by VR (V_o ADJ.) in **section 7.6**.



PDF700S CMFC(D/D-P), PDF700B CMFD(D-P) Series Application Note October V12

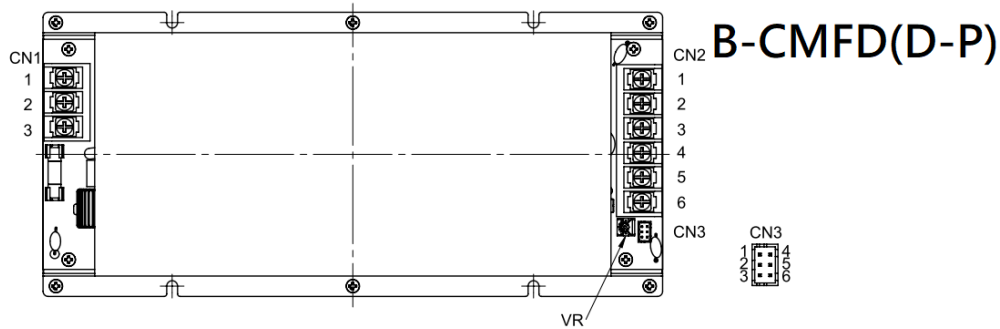

No	CN1	Function	Description
1	FG	Connected to Baseplate	Connected to baseplate (FG)
2	AC1	AC Input	AC Supply Input
3	AC2	AC Input	
--	--	Mounting Insert	Mounting Insert (FG)

No	CN2	Function	Description
1-3	-Vo	-V Output	Negative Power Output
4-6	+Vo	+V Output	Positive Power Output

No	CN3	Function	Description
1	IOG	Monitor Operating Signal	Monitor Normal and Abnormal Operation of The Converter
2	+S	+Sense	Positive output Remote Sense for Only CMFD
3	ON/OFF+	Remote On/Off +	Connect Current Source Between On/Off+ and On/Off- to Remote On/Off The Module
4	ON/OFF-	Remote On/Off -	Connect Current Source Between On/Off+ and On/Off- to Remote On/Off The Module
5	-S	-Sense	Negative Output Remote Sense for Only CMFD
6	TRIM	Trim	External Output Voltage Adjustment for Only CMFD

No	Label	Function	Description
1	VR	V _o ADJ.	Internal Output Voltage Adjustment by Variable Resistor (VR)

Note:

1. The B-CMFD(D-P) means PDF700B-CMFD and PDF700B-CMFD-P series.
2. Baseplate can be connected to FG using M4 mounting insert. Recommended torque 9.6~12.8Kgf-cm.
3. The output voltage of the B-CMFD(D-P) series can be adjusted by VR (V_o ADJ.) in **section 7.6**.



PDF700S CMFC(D/D-P), PDF700B CMFD(D-P) Series Application Note October V12

3. Electrical Diagram

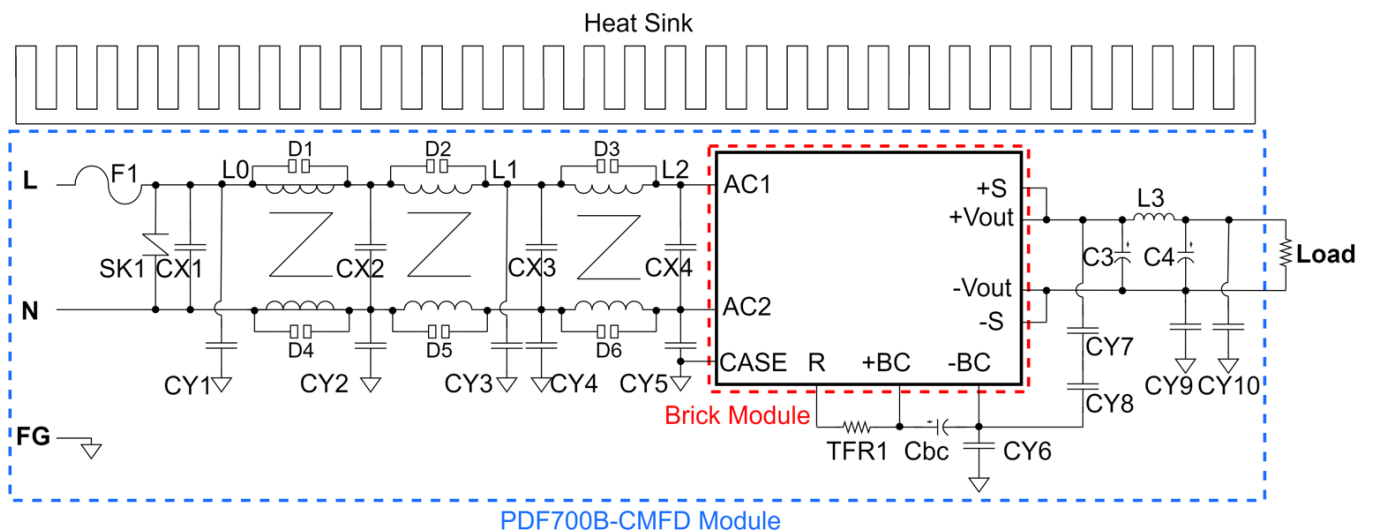
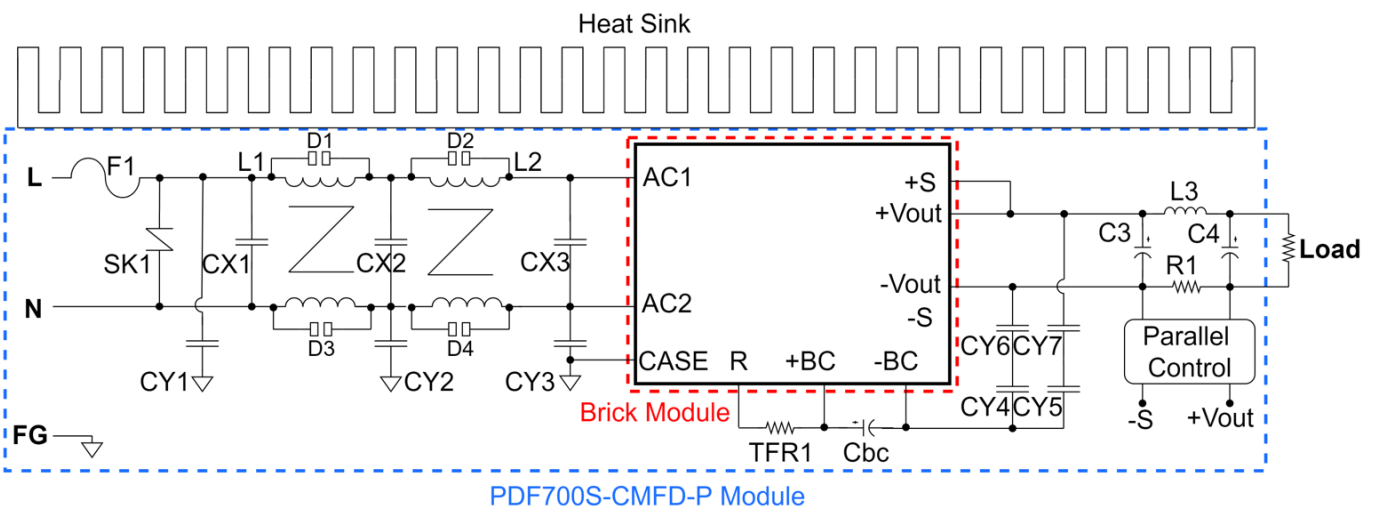
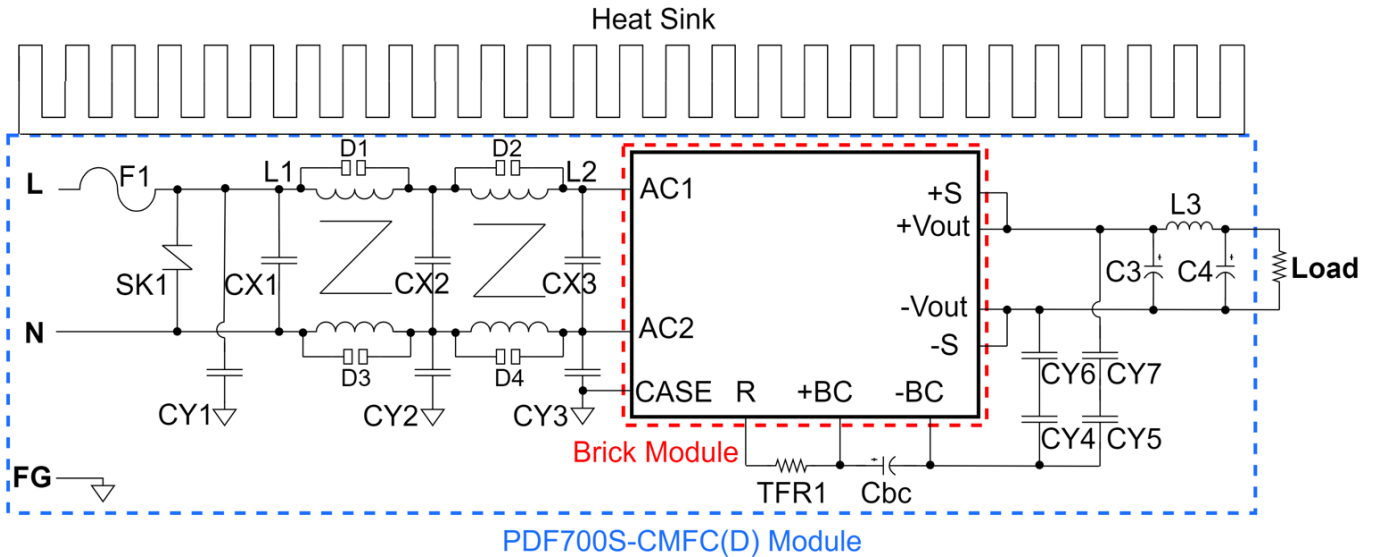



PDF700S CMFC(D/D-P), PDF700B CMFD(D-P) Series Application Note October V12

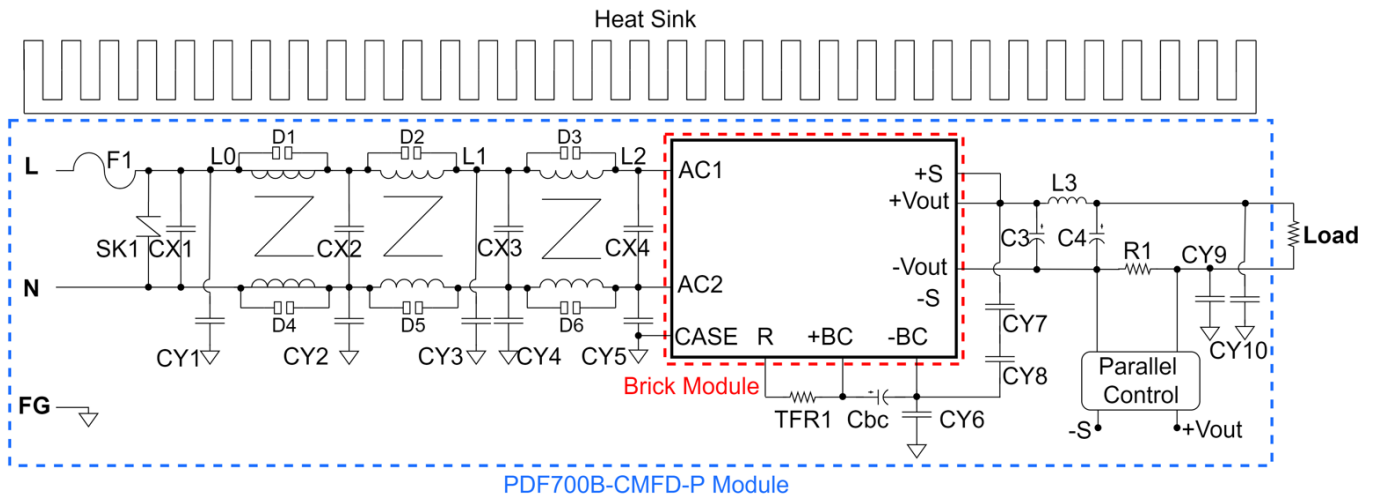

4. Terminal Block

Input and Output Terminal Block (CN1, CN2)

Terminal Type	Screw Torque Value (Kgf-cm)	Suitable Electric Wire (AWG)	Current Rating (max.)
DT-49-B01W-xx or Equivalent	10	12-22	25A



PDF700S CMFC(D/D-P), PDF700B CMFD(D-P) Series Application Note October V12

5. Connection for Standard Use

The connection for standard use is shown below. An EMI filter is recommended for all models to reduce input current noise. The recommended bus capacitor (Cbc) is 880uF (RUBYCON CXW 220uF x4). The TFR1 is used to limit the input inrush current.

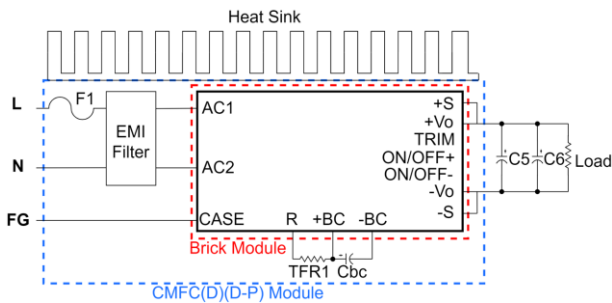

Symbol	Component
F1	Input fuse
EMI Filter	EMI filter on the input side
TFR1	Thermal fuse resistor
Cbc	Capacitor connected between +BC and -BC is necessary to keep operating stable
C5, C6	External capacitor 10 and 0.1uF for ripple and noise on the output side
On/Off+ On/Off-	Remote on/off control
TRIM	Output voltage adjustment
+S, -S	Voltage compensation with \pm sense
Heat Sink	External heat sink

6. Test Set-Up

The basic test set-up to measure parameters such as efficiency and load regulation is shown below. When testing the Cincon's PDF700S-CMFC(D/D-P) and PDF700B-CMFD(D-P) series under any transient conditions, please ensure that the transient response of the source is sufficient to power the equipment under test. We can calculate:

- Efficiency
- Load regulation and line regulation

The value of efficiency is defined as:

$$\eta = \frac{V_o \times I_o}{V_{in} \times I_{in}} \times 100\%$$

Where:

- V_o is output voltage,
- I_o is output current,
- V_{in} is input voltage,
- I_{in} is input current

The value of load regulation is defined as:

$$Load\ reg. = \frac{V_1 - V_2}{V_2} \times 100\%$$

Where:

- V_1 is the output voltage at 20% load
- V_2 is the output voltage at 100% load

The value of line regulation is defined as:

$$Line\ reg. = \frac{V_{HL} - V_{LL}}{V_{LL}} \times 100\%$$

Where:

- V_{HL} is the output voltage of maximum input voltage at full load
- V_{LL} is the output voltage of minimum input voltage at full load

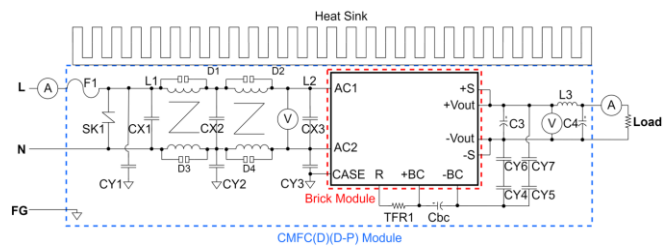

7. Features and Functions

7.1 Over Current Protection

All models have internal over current and continuous short circuit protection. The unit operates normally once the fault condition is removed. At the point of current limit inception, the converter will go into hiccup mode protection.

7.2 Over Voltage Protection

All different voltage models have fully continuous over voltage protection. The power module will supply OVP. In the event of happen the OVP, the converter will shut down, the converter will go into latch mode protection.

7.3 Over Temperature Protection

These modules have an over temperature protection circuit to safeguard against thermal damage. Shutdown occurs with the maximum case reference temperature is exceeded. The module will restart when the case temperature falls below over temperature recovery threshold. The case temperature is the temperature at the center of the baseplate.



PDF700S CMFC(D/D-P), PDF700B CMFD(D-P) Series Application Note October V12

7.4 Remote On/Off

The PDF700S-CMFC(D/D-P) and PDF700B-CMFD(D-P) series allow the user to turn the module on and off electronically with the remote On/Off feature. The converter turns off when the current between the **on/off+** pin and **on/off-** pin is >10mA (20mA max.). Setting the pin current <6mA or open circuit will turn the converter on. If the remote **on/off** pin is not used, leave the pin open (converter will be on). The signal level of remote **on/off+** is defined with respect to **on/off-**.

On/Off Pin Current	Module State
<6mA or Open	Module on
>10mA (20mA max.)	Module off

On/off function Inside connection sees below.

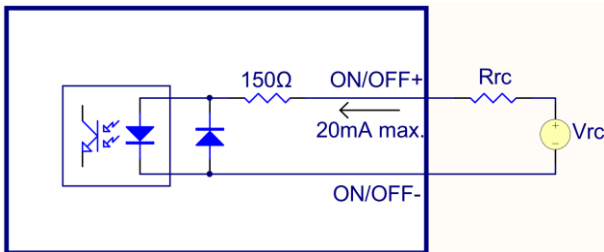

7.5 Output Remote Sensing

This remote sense feature of the PDF700S-CMFD and PDF700B-CMFD(D-P) series move the effective output voltage regulation point from the output of the unit to the point where the remote sense pins are connected. This feature automatically adjusts the actual output voltage of the unit to compensate for voltage drops in the distribution and maintain a regulated voltage at the point of load. The remote sense voltage range is

$$[(+V_{out}) - (-V_{out})] - [(+Sense) - (-Sense)] \leq 5\% \text{ of } V_{o_nominal}$$

Where:

- +V_{out} is +Vo, positive power output,
- V_{out} is -Vo, negative power output,
- +Sense is +S, positive output remote sense,
- Sense is -S, negative output remote sense

When using remote sense, JP1/JP2 must be open and +S/-S must be connected to sense through twisted pair or shielded wire. If the sensing pattern is short-circuited, high current will flow and the pattern may be damaged. The output voltage may become unstable due to the impedance of the wiring and the load condition when the wire length exceeds 400mm. This is shown in the schematic below.

CMFD Module

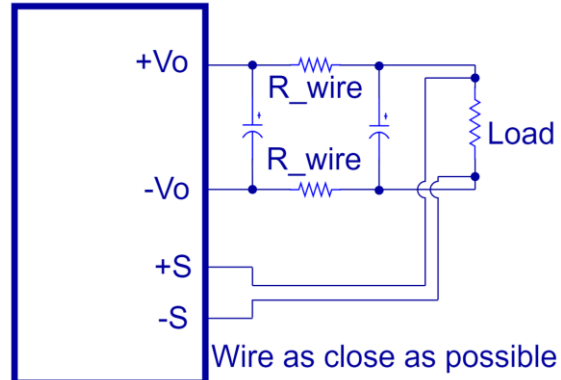

If the remote sense feature of the CMFD series is not to be used, the sense pins should be connected locally by JP1/JP2. The +S pin should be connected to the +Vo pin on the module and the -S pin should be connected to the -Vo pin on the module. The wiring between +S and +Vo and between -S and -Vo should be as short as possible. Avoid loop wiring. The converter may become unstable due to noise from poor wiring. This is shown in the schematic below.

CMFD Module

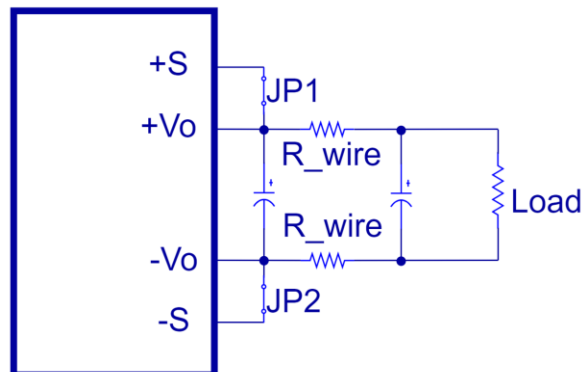

Note:

Although the output voltage can be varied (increased or decreased) by both remote sense and trim, the maximum variation for the output voltage is the sum of the values. The output power delivered by the module is defined as the voltage at the output terminals multiplied by the output current. Using remote sense and trim can increase the output voltage and therefore the output power of the module, if the output current remains unchanged. Always ensure that the output power of the module remains at or below the maximum rated power. Also note that if V_{o,set} is less than the nominal value, P_{out,max.} will also decrease accordingly because I_{o,max.} is an absolute limit. Therefore, P_{out,max.=V_{o,set} x I_{o,max.} is also an absolute limit.}



PDF700S CMFC(D/D-P), PDF700B CMFD(D-P) Series Application Note October V12

7.6 Output Voltage Adjustment

The output voltage can be trimmed (+5% to -5%, (PDF700S560-CMFC(D) and PDF700B560-CMFD: +1.8%, -5%)) with fixed resistors (R12, R13). The position of R12/R13 is shown in the figure below:

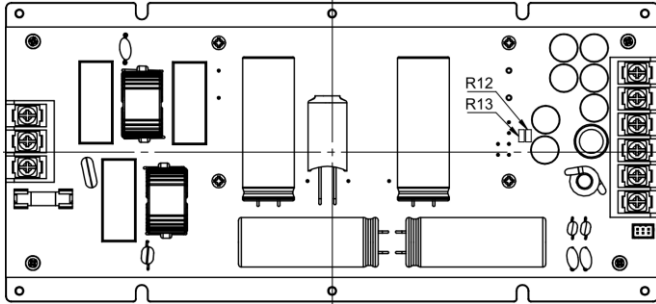

Position of R12/R13

If it is a CMFD(D-P) series, you can even use a variable resistor (VR) to easily adjust the output voltage. $P_o \leq \text{max. rated power}$, $I_o \leq I_{o_max}$. The position of VR is shown in the figure below:

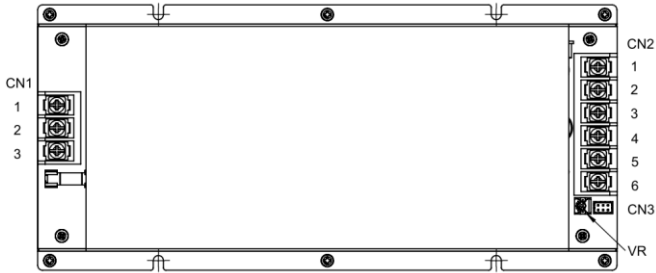

To trim the voltage up or down, the trim resistor $R_{trim\ up}$ (R12) must be connected between the trim pin and -Sense for trim-up or $R_{trim\ down}$ (R13) must be connected between the trim pin and +Sense for trim-down. The output voltage trim range is +5% to -5% (PDF700S560-CMFC(D) and PDF700B560-CMFD +1.8%, -5%). This is shown:

CMFC(D) Module

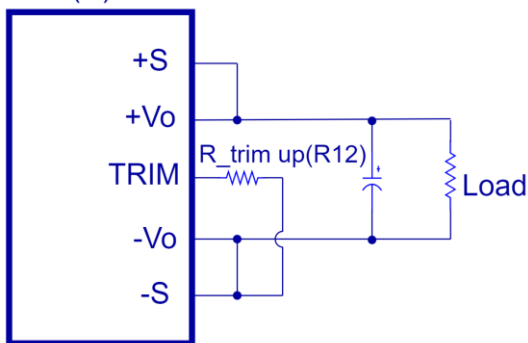

Trim-up Voltage Setup

CMFC(D) Module

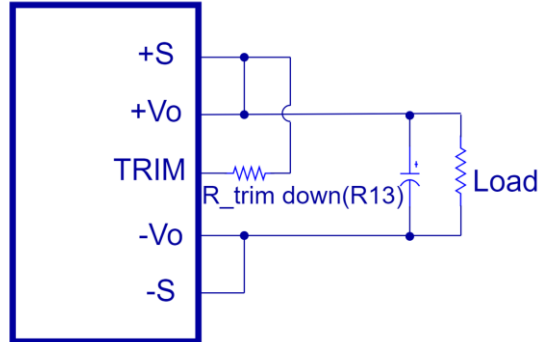

Trim-down Voltage Setup

The PDF700S120-CMFC(D) and PDF700B120-CMFD value of $R_{trim\ up}$ (R12) defined as:

$$R_{trim\ up} = \left[\frac{4950 \times V_{out} - 62640}{180.025 - 15 \times V_{out}} \right] (\text{k}\Omega)$$

The PDF700S240-CMFC(D) and PDF700B240-CMFD value of $R_{trim\ up}$ (R12) defined as:

$$R_{trim\ up} = \left[\frac{8378 \times V_{out} - 213200}{344.875 - 14.35 \times V_{out}} \right] (\text{k}\Omega)$$

The PDF700S280-CMFC(D) and PDF700B280-CMFD value of $R_{trim\ up}$ (R12) defined as:

$$R_{trim\ up} = \left[\frac{9641 \times V_{out} - 285300}{392.025 - 14 \times V_{out}} \right] (\text{k}\Omega)$$

The PDF700S480-CMFC(D) and PDF700B480-CMFD value of $R_{trim\ up}$ (R12) defined as:

$$R_{trim\ up} = \left[\frac{4092 \times V_{out} - 207200}{327.575 - 6.82 \times V_{out}} \right] (\text{k}\Omega)$$

The PDF700S560-CMFC(D) and PDF700B560-CMFD value of $R_{trim\ up}$ (R12) defined as:

$$R_{trim\ up} = \left[\frac{10230 \times V_{out} - 585900}{384.225 - 6.82 \times V_{out}} \right] (\text{k}\Omega)$$



PDF700S CMFC(D/D-P), PDF700B CMFD(D-P) Series Application Note October V12

Where:

$R_{trim\ up}$ is the external resistor in $k\Omega$

V_{out} is the desired output voltage

For example, to trim-up the output voltage of the 12V module (PDF700S120-CMFC(D)) by 5% to 12.6V, $R_{trim\ up}$ (R12) is calculated as follows:

$V_{out}=12.6V$

$$R_{trim\ up} = \left[\frac{4950 \times 12.6 - 62640}{180.025 - 15 \times 12.6} \right] = 30.1(k\Omega)$$

The typical value of $R_{trim\ up}$ (R12)

Trim up (%)	12V	24V	28V	48V
	$R_{trim\ up}$ (R12) ($k\Omega$)			
1%	1491	3408	3248	2884
2%	573.9	1264	1274	1083
3%	271.3	618.4	618.1	509.2
4%	120.4	307.1	290.9	227.3
5%	30.1	123.9	94.7	59.63

For $V_o:56V$

Trim up (%)	56V
	$R_{trim\ up}$ (R12) ($k\Omega$)
1%	4815
1.8%	617.9

The PDF700S120-CMFC(D) and PDF700B120-CMFD value of $R_{trim\ down}$ (R13) defined as:

$$R_{trim\ down} = \left[\frac{3601}{180.025 - 15 \times V_{out}} \right] - 367.95(k\Omega)$$

The PDF700S240-CMFC(D) and PDF700B240-CMFD value of $R_{trim\ down}$ (R13) defined as:

$$R_{trim\ down} = \left[\frac{13380}{344.875 - 14.35 \times V_{out}} \right] - 656.97(k\Omega)$$

The PDF700S280-CMFC(D) and PDF700B280-CMFD value of $R_{trim\ down}$ (R13) defined as:

$$R_{trim\ down} = \left[\frac{17130}{392.025 - 14 \times V_{out}} \right] - 771.44(k\Omega)$$

The PDF700S480-CMFC(D) and PDF700B480-CMFD value of $R_{trim\ down}$ (R13) defined as:

$$R_{trim\ down} = \left[\frac{12250}{327.575 - 6.82 \times V_{out}} \right] - 670(k\Omega)$$

The PDF700S560-CMFC(D) and PDF700B560-CMFD value of $R_{trim\ down}$ (R13) defined as:

$$R_{trim\ down} = \left[\frac{37500}{384.225 - 6.82 \times V_{out}} \right] - 1378(k\Omega)$$

Where:

$R_{trim\ down}$ is the external resistor in $k\Omega$

V_{out} is the desired output voltage

For example, to trim-down the output voltage of the 12V module by 5% to 11.4V, $R_{trim\ down}$ (R13) is calculated as follows:

$V_{out}=11.4V$

$$R_{trim\ down} = \left[\frac{3601}{180.025 - 15 \times 11.4} \right] - 367.95 = 31(k\Omega)$$

The typical value of $R_{trim\ down}$ (R13)

Trim down (%)	12V	24V	28V	48V	56V
	$R_{trim\ down}$ (R13) ($k\Omega$)				
1%	1605	2757	3571	2841	4501
2%	625.4	1160	1407	1142	2149
3%	295.8	581.1	682.1	550.6	1103
4%	130.5	281.9	319.3	250.4	510.9
5%	31	99.2	101.4	68.7	130.2

7.7 IOG Signal

Normal and abnormal operation of the converter can be monitored using the IOG signal. The output of this signal monitor is on the secondary side and is open collector output, we can use the external DC supply as shown in the following figure. The ground reference is the $-V_o$. If you want to use the IOG function, you need to connect $-V_o$ PIN and IOG PIN of CN3 to operate.

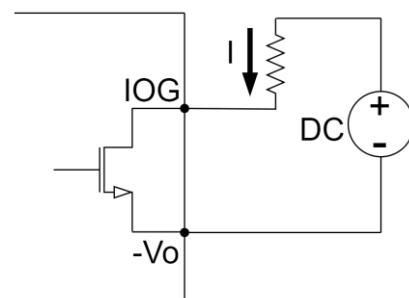

External DC supply (DC: 50 $V_{max.}$, I: 0.1 $A_{max.}$)

This signal is low when the converter is operating normally and high when the converter is disabled or operating abnormally.

Also note that IOG becomes unstable for under the following conditions:

- Operation of over current protection (OCP)
- Light load conditions
- Dynamic load operation



PDF700S CMFC(D/D-P), PDF700B CMFD(D-P) Series Application Note October V12

8. Input/Output Considerations

8.1 Hold Up Time

Capacitor Cbc is used for the hold-up time function. When the input power supply is interrupted, the PDF700S-CMFC(D/D-P) and PDF700B-CMFD(D-P) series use the energy stored in Cbc to support operation. A typical configuration is shown below.

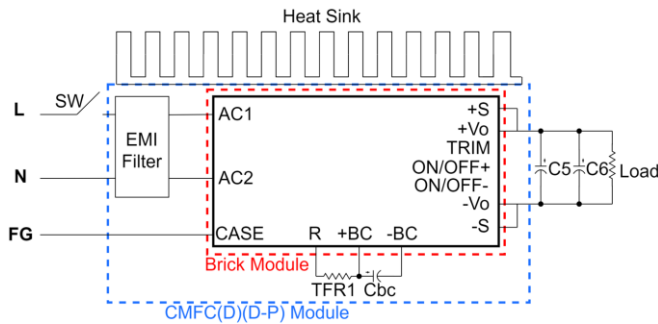

The capacitance of Cbc in the PDF700S-CMFC(D/D-P) and PDF700B-CMFD(D-P) is 880uF and the corresponding hold up time is 16 mS. However, if Cbc is changed to 660uF, the hold time becomes 10 mS. The recommended capacitance range of the capacitor (Cbc) is 660~2200uF.

Hold up time	Capacitance	Cbc
10mS		220uF x 3
16mS		220uF x 4

8.2 Inrush Current Limiting Resistor TRF1

The TRF1 resistor is used to limit the primary inrush current. It must be connected between R and +BC. If this resistor is not connected, the power supply will not operate. TRF1 is a cemented resistor with over-temperature protection. It should have a high inrush current capability. TRF1 for PDF700S-CMFC(D/D-P) series is 10Ω, while its resistance value is recommended to be in the range of 4.7Ω to 22Ω.

8.3 Derating Curve

The PDF700S-CMFC(D/D-P) and PDF700B-CMFD(D-P) series have a derating curve as shown below.

Input Voltage Derating Curve

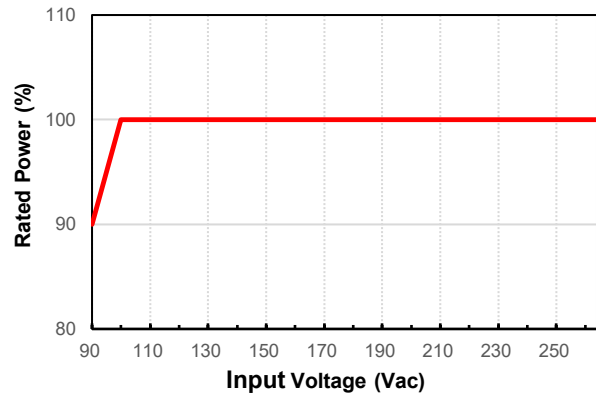

Case Temperature Derating Curve

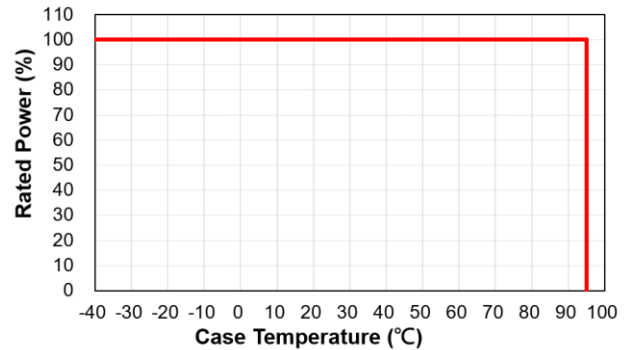

8.4 Output Ripple and Noise

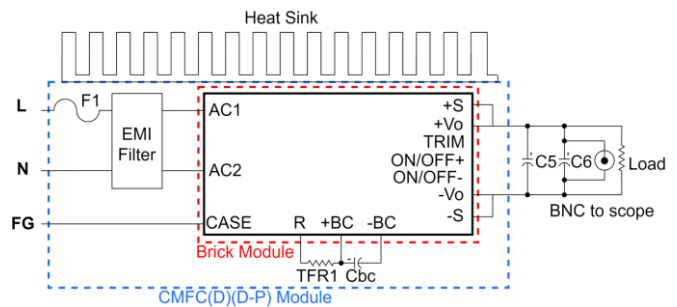

Output ripple and noise measured with 10uF aluminum capacitor and 1uF ceramic capacitors across output. A 20 MHz bandwidth oscilloscope is normally used for this measurement.

The conventional ground clip on an oscilloscope probe should never be used for this type of measurement. This clip, when placed in a field of radiated high frequency energy, acts as an antenna or inductive pickup loop and produces an extraneous voltage that is not part of the converter's output noise.



PDF700S CMFC(D/D-P), PDF700B CMFD(D-P) Series Application Note October V12



Another method is shown in below, in case of coaxial-cable/BNC is not available. The noise pickup is eliminated by pressing scope probe ground ring directly against the -Vout terminal while the tip contacts the +Vout terminal. This makes the shortest possible connection across the output terminals.

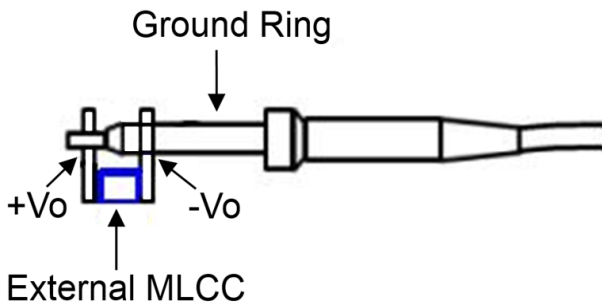

8.5 Series Operation

Two or more PDF700S-CMFC(D) or PDF700B-CMFD can be connected to realize series operation. The connection method is shown below. The series output current should be less than the rated current of each power module.

The PDF700S(B)-CMFD-P cannot be used for serial operation.

The PDF700S(B)-CMFD-P is a product designed for parallel operation and the output voltage fluctuates with the load level. Therefore, the PDF700S(B)-CMFD-P is not recommended for series operation.

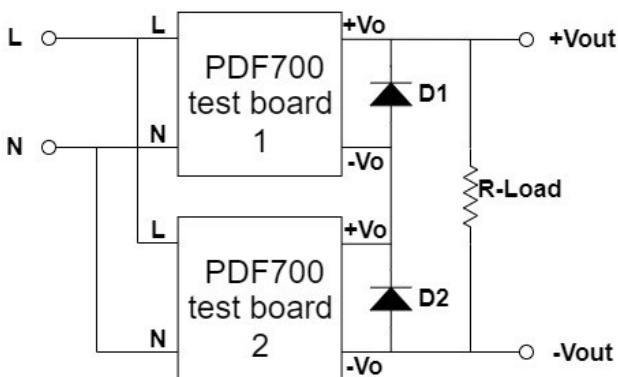

Simple Series Operation Connect Circuit

Note:

1. L/N: Input voltage 90~264V_{ac}.
2. The PDF700 test board means PDF700S-CMFC(D) or PDF700B-CMFD, chassis mount module. The detailed components are introduced in **section 8.7**.
3. It is recommended that a Schottky diode (D1, D2) be connected across the output of each series connected converter, and the external diode should be capable of handling the full load current for as long as the application is expected to run with each unit shut down.

Series connection for ±output operation is possible by connecting the outputs of two units as shown in the schematic below.

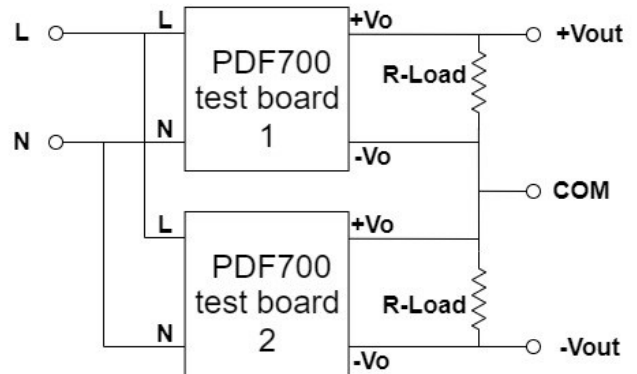

Simple ±Output Operation Connect Circuit

Note:

1. L/N: Input voltage 90~264V_{ac}.
2. The PDF700 test board means PDF700S-CMFC(D) or PDF700B-CMFD, chassis mount module. The detailed components are introduced in **section 8.7**.



PDF700S CMFC(D/D-P), PDF700B CMFD(D-P) Series

Application Note October V12

8.6 Parallel Operation

The PDF700S(B)-CMFD-P is specifically designed for parallel operation and can be used with two or more units operating in parallel. In addition to parallel operation, it is also possible to connect each output for N+1 redundant operation.

If parallel operation is required, it is recommended to use the CMFD series with the CSC01 module or only the CMFD-P series, as the CMFC series cannot be operated in parallel. The operation of CSC01 can be found in the CSC01 application note.

The PDF700S(B)-CMFD-P utilizes the inherent “voltage droop” created in the negative output to allow two or more power supplies to share current and provides a simple connection method for current sharing. It uses voltage droop technology to achieve relatively equal current distribution between power modules by relying on the output characteristics of parallel modules.

The PDF700S(B)-CMFD-P is easy to connect because the parallel system does not need to be connected to a share bus. Parallel operation is possible by connecting the units as shown below.

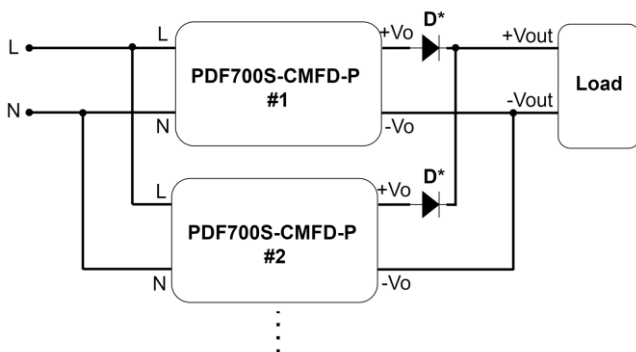

Example of Wiring for Parallel Operation

Note:

1. The PDF700S(B)-CMFD-P series is designed with voltage droop technology so that the output voltage is 1.05 times the rated voltage at no load and drops to the rated voltage at full load.
2. It is recommended that the number of PDF700S(B)-CMFD-P units connected in parallel should not exceed 8 units. The electrical characteristics of the entire parallel system will be different from that of a single unit. There may be EMI, leakage current, surge current or other characteristics that do not meet the specification in parallel.
3. It is recommended that the output voltage error of each unit be adjusted to less than 0.3% before paralleling, the smaller the accuracy, the better.
4. When paralleling, it is necessary to avoid the overcurrent protection (OCP) trig during startup, and the following should be observed:
 - (a). To avoid OCP, the total load current should be less than the rated current of one unit before all parallel units have completed startup.
 - (b). Set the output voltages of each unit to the same voltage. It is recommended that the voltage difference between each unit be less than 0.3%.
 - (c). The output conductors/cables must be of the same length and gauge to avoid different voltage drops.
 - (d). The maximum total power after parallel operation is recommended to be 85% of the total rated power.
5. If the temperature of the aluminum baseplate varies during parallel operation, the difference in output current may be significant. Therefore uniform and sufficient heat dissipation is required.
6. It is recommended to use the remote **on/off** function to send a remote **on/off** signal to each parallel unit at the same time. This ensures that the parallel units can be started at the same time during remote **on/off** control.
7. The ORing diodes (D*) allow current to flow in one direction, isolating the fault units and allowing the system to continue operating with the remaining units. The ORing diode (D*) is recommended in the parallel system. It is recommended that the repetitive peak reverse voltage (V_{RRM}) of the ORing diode be more than 1.2 times the rated voltage of the converter, and the average forward current ($I_{F(AV)}$) be 2 times the rated current of the converter. The forward voltage drop (V_F) of the diode, the lower the better, dissipates power and generates heat, so better thermal management is needed.

V_{RRM} : V_{RRM} is called repetitive peak reverse voltage or repetitive peak reverse bias. Applying a negative voltage to the anode side relative to the cathode is reverse bias, and the applied voltage is reverse bias.

$I_{F(AV)}$: $I_{F(AV)}$ is called the average forward current. The current flowing through a diode when a forward voltage is applied is called forward current.

V_F : V_F is called forward voltage drop or forward bias. A positive voltage is applied to the anode side of the diode and a negative voltage is applied to the cathode side, which is called forward bias, and the applied voltage is forward bias.



PDF700S CMFC(D/D-P), PDF700B CMFD(D-P) Series Application Note October V12

Example of parallel operation:

Operate two PDF700S(B)120-CMFD-P units in parallel at the maximum recommended parallel output current (85% Load). The steps are as follows:

Step 1. With no load, adjust the output voltage of each PDF700S(B)120-CMFD-P via VR to +5%, i.e. 12.6 V. The difference in output voltage between the two units should be within 0.3%, the smaller the better. See the table below.

Operation in Parallel	Output Voltage (No Load)	Recommended maximum parallel output current (85% Load Per Unit)	Output Voltage (Full Load)
PDF700S(B)120-CMFD-P	12V+5%=12.6V	50A	12V
PDF700S(B)240-CMFD-P	24V+5%=25.2V	25A	24V
PDF700S(B)280-CMFD-P	28V+5%=29.4V	21.4A	28V
PDF700S(B)480-CMFD-P	48V+5%=50.4V	12.5A	48V
PDF700S(B)560-CMFD-P	54V+5%=56.7V	11.1A	54V

For PDF700S(B)560-CMFD-P, it is recommended to set the output voltage to 54V instead of 56V for parallel operation due to OVP.

Step 2. The ORing (D*) diode is required. When connecting two PDF700S(B)120-CMFD-P units in parallel, the repetitive peak reverse voltage (V_{RRM}) and the average forward current ($I_{F(AV)}$) of the ORing diode (D*) must meet the recommended values as suggested in the table below.

ORing diode (D*)	Repetitive Peak Reverse Voltage (V_{RRM})	Average Forward Current ($I_{F(AV)}$)
PDF700S(B)120-CMFD-P	15V	50*2=100A
PDF700S(B)240-CMFD-P	30V	25*2=50A
PDF700S(B)280-CMFD-P	35V	21.4*2=42.8A
PDF700S(B)480-CMFD-P	60V	12.5A*2=25A
PDF700S(B)560-CMFD-P	70V	11.1*2=22.2A

After connecting two PDF700S(B)120-CMFD-P units in parallel, connect the remote **on/off** control lines of both units. Set the recommended maximum parallel output current per unit (85%):

$$700W \times 85\% = 600W, 600W/12V = 50A$$

Step 3. Supply 3V to the remote **on/off** control line to control the parallel system in the remote off state. See **section 7.4 Remote on/off** for how to use this function.

Step 4. Supply input voltage to the parallel system, as the output voltage is 0V in the remote off state.

Step 5. The remote **on/off** control line voltage is switched from 3V to 0V and the parallel system control is switched to the remote on state. At this point the parallel system has an output current of 100A and an output voltage of approximately 12V.



PDF700S CMFC(D/D-P), PDF700B CMFD(D-P) Series Application Note October V12

8.7 EMC Considerations

PDF700S-CMFC(D) :

EMI Test Standard: EN 55032 (EN 55022) Class A Conducted & Radiated Emission

Test Condition: Input Voltage: 230V_{ac}, Output Load: Full Load

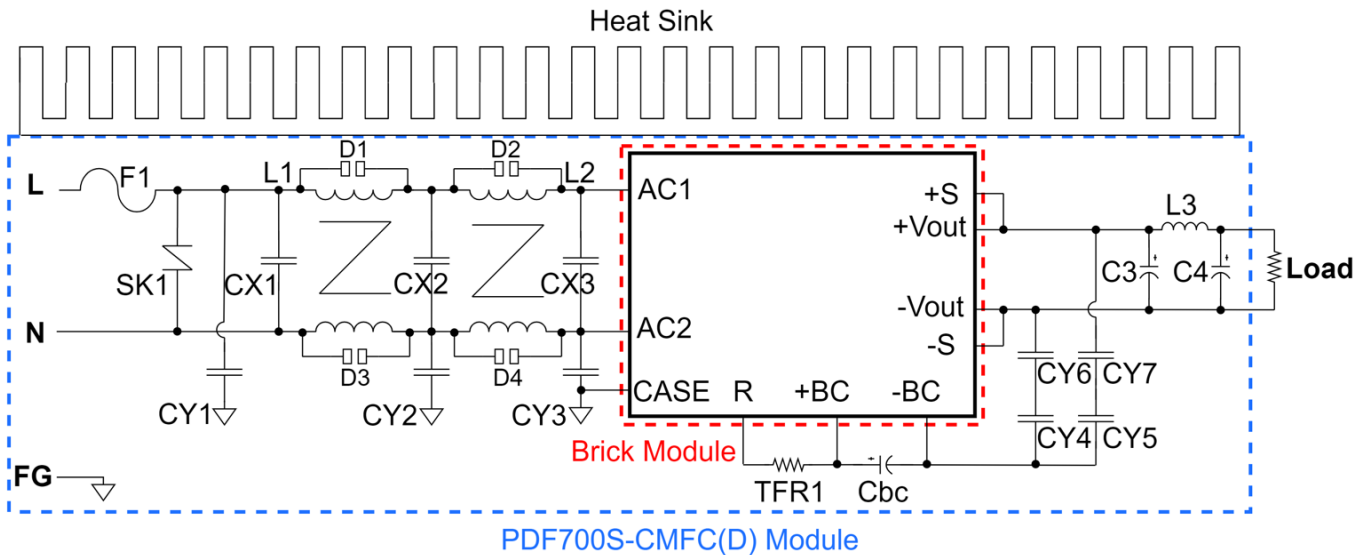

EN 55032 Class A					
Model Number					
	PDF700S120-CMFC(D/D-P)	PDF700S240-CMFC(D/D-P)	PDF700S280-CMFC(D/D-P)	PDF700S480-CMFC(D/D-P)	PDF700S560-CMFC(D/D-P)
F1	15A 250V	15A 250V	15A 250V	15A 250V	15A 250V
SK1	Ø10 470V	Ø 10 470V	Ø 10 470V	Ø 10 470V	Ø 10 470V
D1, D2 D3, D4	200V/3000A	200V/3000A	200V/3000A	200V/3000A	200V/3000A
CX1, CX2, CX3	2.2uF/310V	2.2uF/310V	2.2uF/310V	2.2uF/310V	2.2uF/310V
C3	1200uF/16V×7 parallel	1000uF/35V×7 parallel	1000uF/35V×7 parallel	470uF/63V×4 & 270uF/63V×3 parallel	470uF/63V×4 & 270uF/63V×3 parallel
C4	2200uF/16V	1000uF/35V	1000uF/35V	390uF/63V	390uF/63V
Cbc	220uF/450V×4 parallel	220uF/450V×4 parallel	220uF/450V×4 parallel	220uF/450V×4 parallel	220uF/450V×4 parallel
CY1	1000pF/400VAC	1000pF/400VAC	1000pF/400VAC	1000pF/400VAC	1000pF/400VAC
CY2	4700pF/400VAC	4700pF/400VAC	4700pF/400VAC	4700pF/400VAC	4700pF/400VAC
CY3, CY4, CY5, CY6, CY7	470pF/400VAC	470pF/400VAC	470pF/400VAC	470pF/400VAC	470pF/400VAC
TFR1	10R	10R	10R	10R	10R
L1	33mH typ.	33mH typ.	33mH typ.	33mH typ.	33mH typ.
L2	6mH typ.	6mH typ.	6mH typ.	6mH typ.	6mH typ.
L3	0.06uH min.	Short	Short	Short	Short
CY1 (GND)	BEAD CORE	BEAD CORE	BEAD CORE	BEAD CORE	BEAD CORE
CY2					
CY4(-BC)					
CY5(-BC)					



PDF700S CMFC(D/D-P), PDF700B CMFD(D-P) Series Application Note October V12

Note:

CX1~CX3 : X2 capacitors

C3: aluminum polymer capacitors

Cbc, C4: aluminum capacitors

CY1~CY7: Y1 ceramic capacitors

F1: Fuse 15A/250V

SK1: VARISTOR/470V (TKS TVR10471KSV) or equivalent

D1, D2, D3, D4: 200V 3000A (BRIGHTKING BK1 series) or equivalent

CX1, CX2, CX3: 2.2uF/310V (HJC MKP series) or equivalent

C3:

1200uF/16V (GEMCON GPH series) or equivalent

1000uF/35V (AISHI PV series) or equivalent

270uF/63V (AISHI PV series) or equivalent

470uF/63V (AISHI PV series) or equivalent

C4:

2200uF/16V (RUBYCON ZLH series) or equivalent

1000uF/35V (NCC KY series) or equivalent

390uF/63V (RUBYCON ZLH series) or equivalent

Cbc: 220uF/450V (RUBYCON CXW series) or equivalent

L1: COMMON CHOKE T20*12*8C/NANOCRYSTAL / ϕ 1.0mm/22T

L2: COMMON CHOKE T20*12*10C/R15K/ ϕ 1.0mm/20T

L3: INDUCTOR DIP R6*20/ ϕ 2.5mm/0.06uH MIN.

TFR1:

Cement resistor 10R (SET FUSE TPR5 series) or equivalent

(Life time of TFR1 is affected by watt of TFR1 and capacitance value of Cbc)

CY1: 1000pF/400VAC (TDK CD series) or equivalent

CY2: 4700pF/400VAC (TDK CD series) or equivalent

CY3, CY4, CY5, CY6, CY7: 470pF/400VAC (TDK CD series) or equivalent

CY2、CY4 (-BC)、CY5 (-BC) : BEAD CORE A6B T 3.5*3*1.2mm KING CORE

CY1 (GND): BEAD CORE N4L T3.0*1.2*1.62 ATC



PDF700S CMFC(D/D-P), PDF700B CMFD(D-P) Series Application Note October V12

PDF700B-CMFD :

EMI Test Standard: EN 55032 (EN 55022) Class B Conducted & Radiated Emission

Test Condition: Input Voltage: 230V_{ac}, Output Load: Full Load

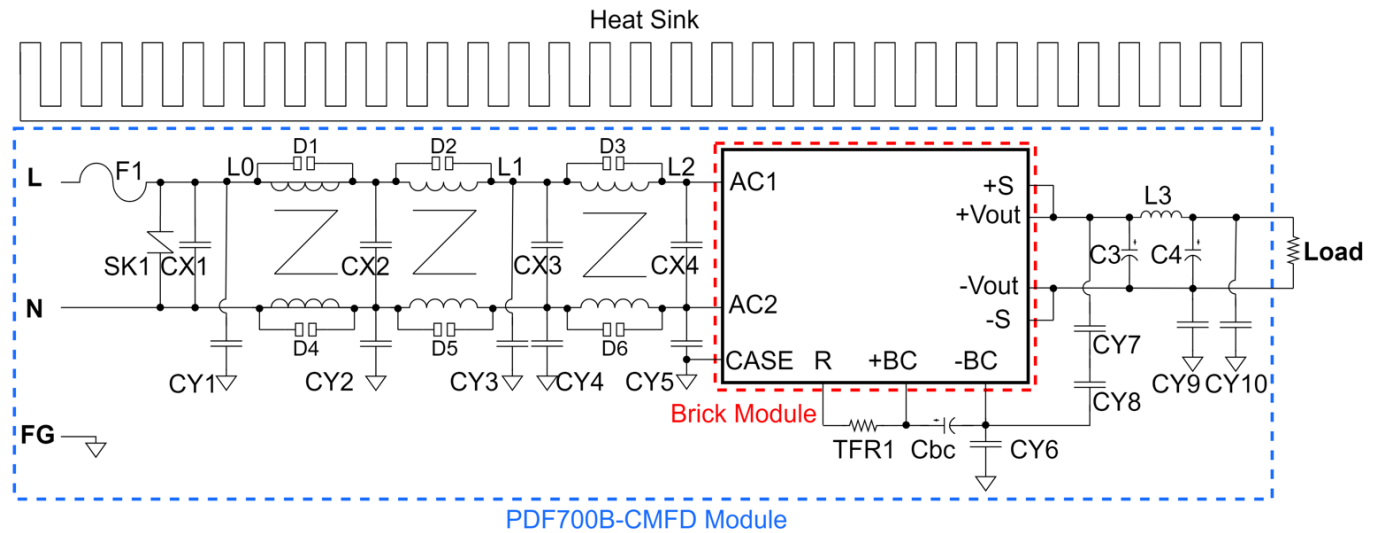

PDF700B-CMFD Module

	EN 55032 Class B				
	Model Number				
	PDF700B120-CMFD(D-P)	PDF700B240-CMFD(D-P)	PDF700B280-CMFD(D-P)	PDF700B480-CMFD(D-P)	PDF700B560-CMFD(D-P)
F1	15A 250V	15A 250V	15A 250V	15A 250V	15A 250V
SK1	Ø10 470V	Ø 10 470V	Ø 10 470V	Ø 10 470V	Ø 10 470V
D1, D2, D3, D4, D5, D6	200V/3000A	200V/3000A	200V/3000A	200V/3000A	200V/3000A
CX1	1uF/310V	1uF/310V	1uF/310V	1uF/310V	1uF/310V
CX2, CX3, CX4	2.2uF/310V	2.2uF/310V	2.2uF/310V	2.2uF/310V	2.2uF/310V
C3	1200uF/16V×6 parallel	1000uF/35V×6 parallel	1000uF/35V×6 parallel	470uF/63V×4 & 270uF/63V×2 parallel	470uF/63V×4 & 270uF/63V×2 parallel
C4	2200uF/16V	1000uF/35V	1000uF/35V	390uF/63V	390uF/63V
Cbc	220uF/450V×4 parallel	220uF/450V×4 parallel	220uF/450V×4 parallel	220uF/450V×4 parallel	220uF/450V×4 parallel
CY1	2200pF/400VAC	2200pF/400VAC	2200pF/400VAC	2200pF/400VAC	2200pF/400VAC
CY2	680pF/400VAC	680pF/400VAC	680pF/400VAC	680pF/400VAC	680pF/400VAC
CY3, CY6	1000pF/400VAC	1000pF/400VAC	1000pF/400VAC	1000pF/400VAC	1000pF/400VAC
CY4, CY9, CY10	330pF/400VAC	330pF/400VAC	330pF/400VAC	330pF/400VAC	330pF/400VAC
CY5	100pF/400VAC	100pF/400VAC	100pF/400VAC	100pF/400VAC	100pF/400VAC
CY7, CY8	470pF/400VAC	470pF/400VAC	470pF/400VAC	470pF/400VAC	470pF/400VAC
TFR1	10R	10R	10R	10R	10R
L0, L1	33mH typ.	33mH typ.	33mH typ.	33mH typ.	33mH typ.
L2	6mH typ.	6mH typ.	6mH typ.	6mH typ.	6mH typ.
L3	0.06uH min.	Short	Short	Short	Short



PDF700S CMFC(D/D-P), PDF700B CMFD(D-P) Series

Application Note October V12

EN 55032 Class B					
Model Number					
	PDF700B120-CMFD(D-P)	PDF700B240-CMFD(D-P)	PDF700B280-CMFD(D-P)	PDF700B480-CMFD(D-P)	PDF700B560-CMFD(D-P)
CY1 (GND)	BEAD CORE	BEAD CORE	BEAD CORE	BEAD CORE	BEAD CORE
CY2 (L0)					
CY3 (L1)					
CY4 (L1)					
CY5 (L2)					
CY6					
CY8 (-BC)					
CY10 (+Vo)					

Note:

CX1~CX4 : X1/X2 capacitors

C3: aluminum polymer capacitors

Cbc, C4: aluminum capacitors

CY1~CY10: Y1 ceramic capacitors

F1: Fuse 15A/250V

SK1: VARISTOR/470V (TKS TVR10471KSV) or equivalent

D1, D2, D3, D4, D5, D6: 200V 3000A (BRIGHTKING BK1 series) or equivalent

CX1: 1uF/310V (CT CTX series) or equivalent

CX2, CX3, CX4: 2.2uF/310V (HJC MKP series) or equivalent

C3:

1200uF/16V (GEMCON GPH series) or equivalent

1000uF/35V (AISHI PV series) or equivalent

270uF/63V (AISHI PV series) or equivalent

470uF/63V (AISHI PV series) or equivalent

C4:

2200uF/16V (RUBYCON ZLH series) or equivalent

1000uF/35V (NCC KY series) or equivalent

390uF/63V (RUBYCON ZLH series) or equivalent

Cbc: 220uF/450V (RUBYCON CXW series) or equivalent

L0, L1: COMMON CHOKE T20*12*8C/NANOCRYSTAL / ϕ 1.0mm/22T

L2: COMMON CHOKE T20*12*10C/R15K/ ϕ 1.0mm/20T

L3: INDUCTOR DIP R6*20/ ϕ 2.5mm/0.06uH MIN.

TFR1:

Cement resistor 10R (SET FUSE TPR5 series) or equivalent

(Life time of TFR1 is affected by watt of TFR1 and capacitance value of Cbc)

CY1: 2200pF/400VAC (TDK CD series) or equivalent

CY2: 680pF/400VAC (TDK CD series) or equivalent

CY3, CY6: 1000pF/400VAC (TDK CD series) or equivalent

CY4, CY9, CY10: 330pF/400VAC (TDK CD series) or equivalent

CY5: 100pF/400VAC (TDK CD series) or equivalent

CY7, CY8: 470pF/400VAC (TDK CD series) or equivalent

CY1 (GND) · CY6: BEAD CORE A6B T 3.5*3*1.2mm KING CORE

CY2 (L0) · CY3 (L1) · CY4 (L1) · CY5 (L2) · CY8 (-BC) · CY10 (+Vo): BEAD CORE N4L T3.0*1.2*1.62 ATC



PDF700S CMFC(D/D-P), PDF700B CMFD(D-P) Series Application Note October V12

Conducted Emission for PDF700S-CMFD Class A

PDF700S120-CMFD

Line

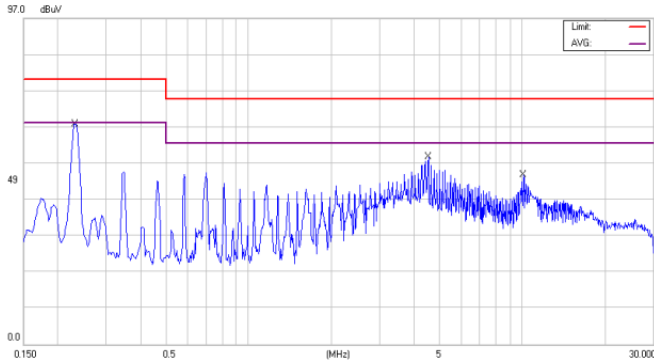

Neutral

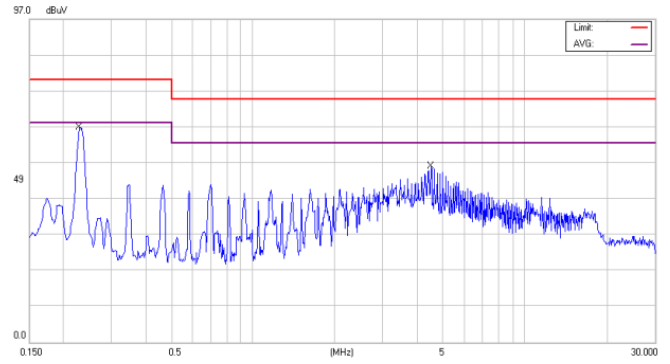

PDF700S240-CMFD

Line

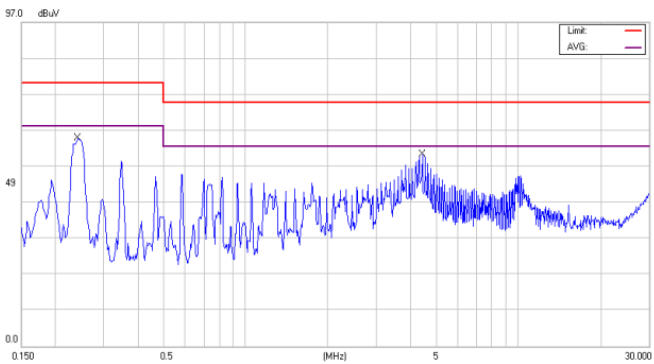

Neutral

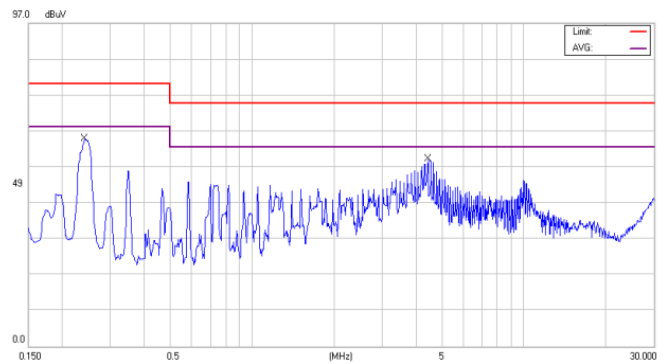

PDF700S280-CMFD

Line

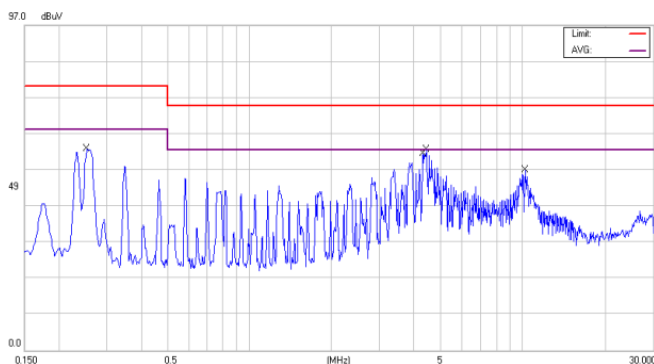

Neutral

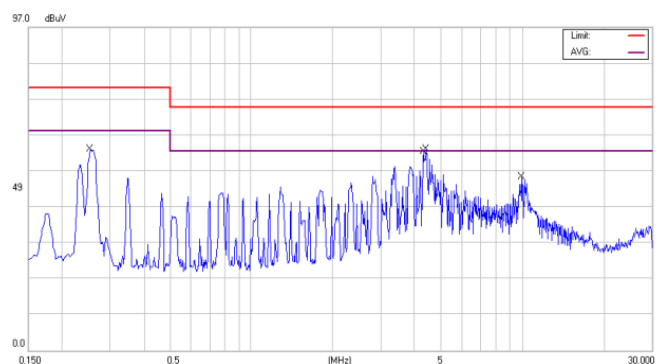



PDF700S CMFC(D/D-P), PDF700B CMFD(D-P) Series Application Note October V12

PDF700S480-CMFD

Line

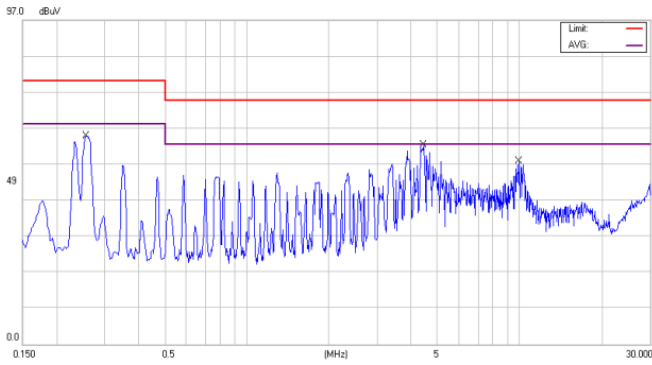

Neutral

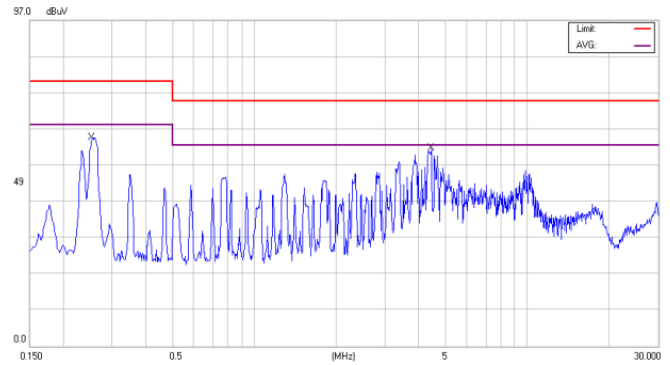

PDF700S560-CMFD

Line

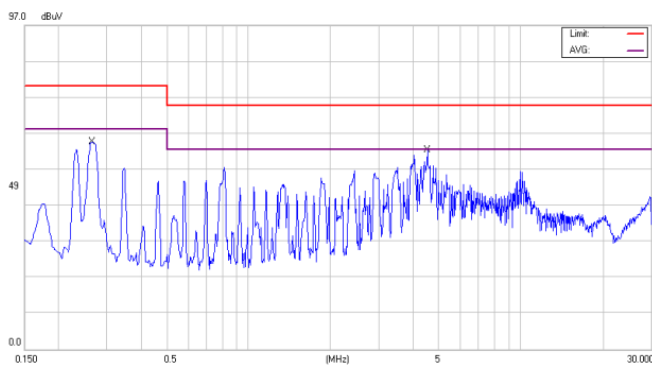

Neutral

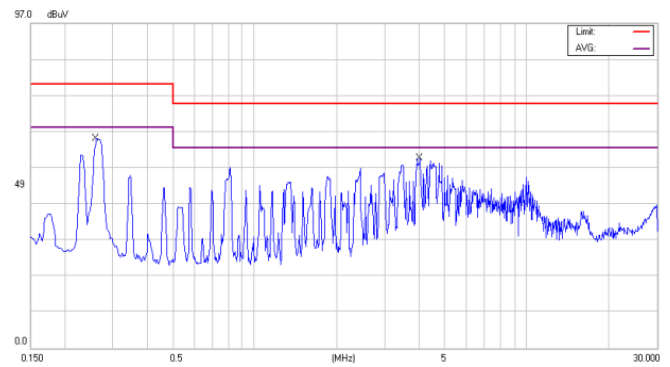



PDF700S CMFC(D/D-P), PDF700B CMFD(D-P) Series Application Note October V12

Conducted Emission for PDF700B-CMFD Class B

PDF700B120-CMFD

Line

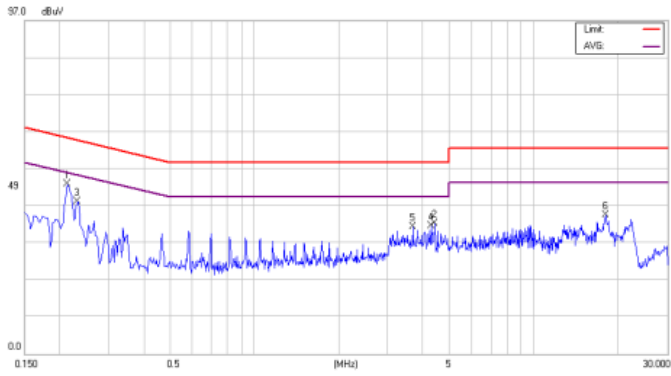

Neutral

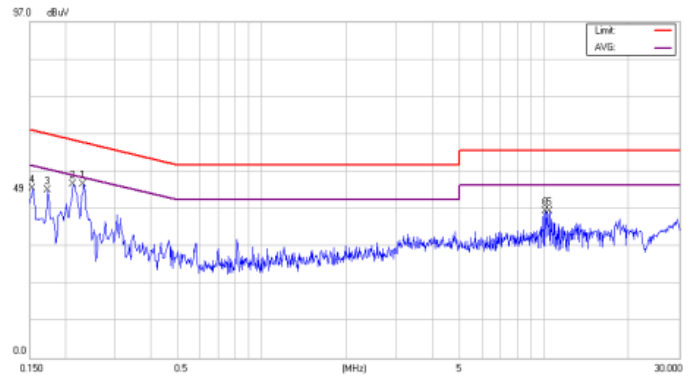

PDF700B240-CMFD

Line

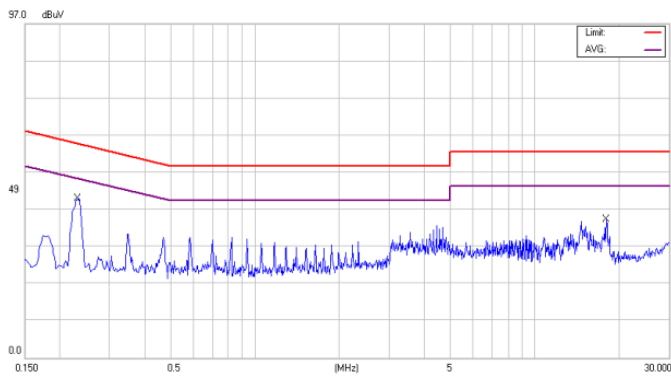

Neutral

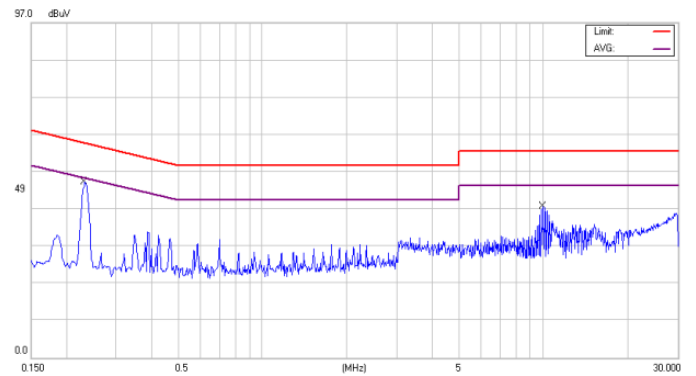

PDF700B280-CMFD

Line

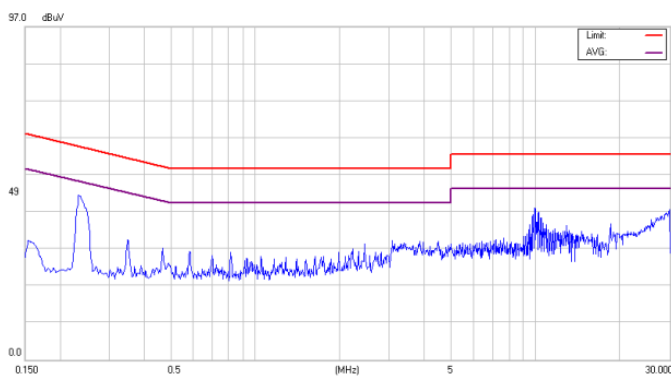

Neutral

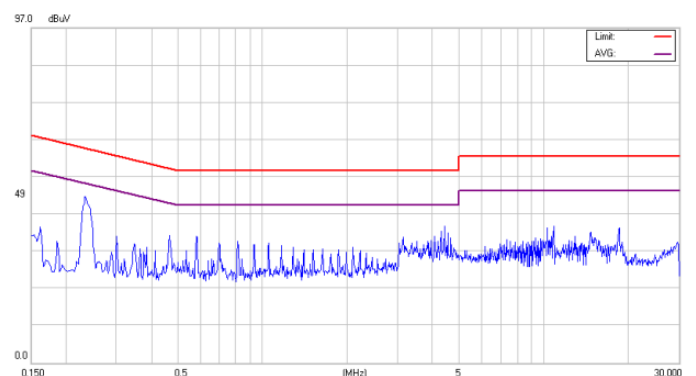



PDF700S CMFC(D/D-P), PDF700B CMFD(D-P) Series Application Note October V12

PDF700B480-CMFD

Line

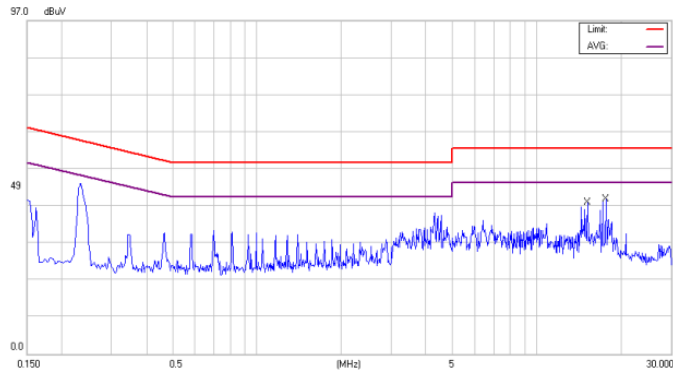

Neutral

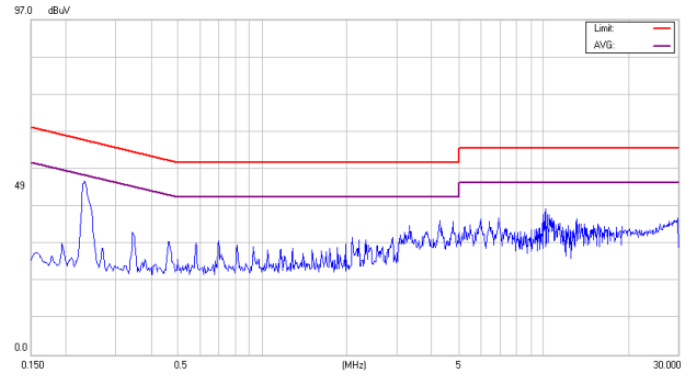

PDF700B560-CMFD

Line

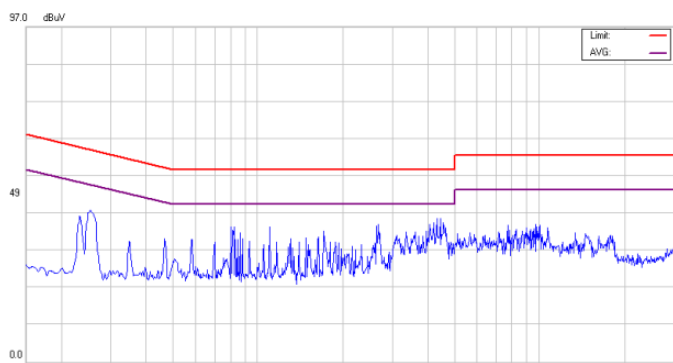

Neutral

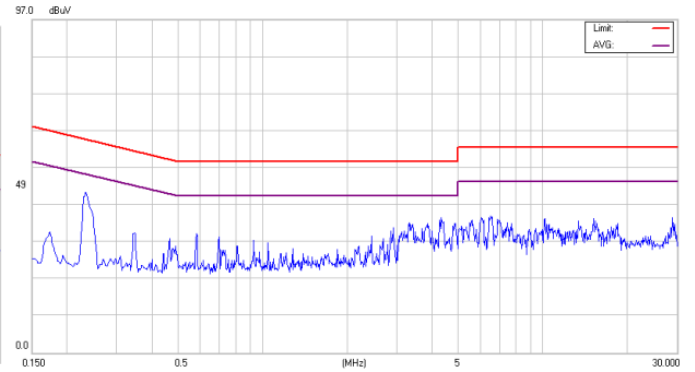



PDF700S CMFC(D/D-P), PDF700B CMFD(D-P) Series Application Note October V12

9. Thermal Design

9.1 Operating Temperature Range

The highly efficient design of Cincon's PDF700S-CMFC(D/D-P) and PDF700B-CMFD(D-P) series power modules have resulted in their ability to operate within case operating temperature range of -40°C to 95°C, measured at the center of the baseplate. The derating curves must be taken into account when determining the maximum power that can be drawn from the module. The maximum power that can be drawn is influenced by a number of factors, such as:

- Input voltage range
- Permissible Output load (per derating curve)
- Forced air or natural convection
- Heat sink (optional)

9.2 Convection Cooling Requirements

To predict the approximate cooling requirements for the full brick module, refer to the power derating curves in **section 8.3**. These derating curves are approximations of the ambient temperatures and airflows required to keep the power module temperature below its maximum rating. Once the module is installed in the actual system, the module temperature should be monitored to ensure that it does not exceed 95°C measured at the center of the baseplate.

9.3 Thermal Considerations

The power module operates in a variety of thermal environments; however, sufficient cooling should be provided to ensure reliable operation of the unit. Heat is dissipated to the environment by conduction, convection, and radiation. See **section 8.3** for example. The power output of the module should not exceed the rated power ($V_{o_set} \times I_{o_max}$).



PDF700S CMFC(D/D-P), PDF700B CMFD(D-P) Series Application Note October V12

9.4 Power Derating

The operating case temperature range of the PDF700S-CMFC(D/D-P) and PDF700B-CMFD(D-P) series are -40°C to +95°C. Proper derating or cooling is needed When operating the PDF700S-CMFC(D/D-P) or PDF700B-CMFD(D-P) series. The maximum case temperature measured at the center of the baseplate should not exceed 95 °C under any operating condition. The following curve is the derating curve of PDF700S-CMFC(D/D-P) or PDF700B-CMFD(D-P) series with heat sink.

Note1: Pd is calculated after 1 minute of burn-in.

Note2: Maximum ambient temperature is limited at 85°C to be considered the life time of the electrolytic capacitor.

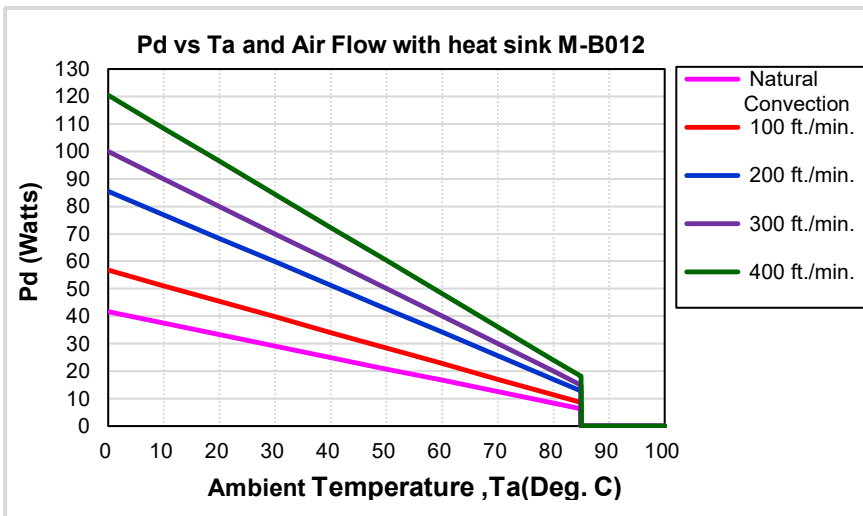

AIR FLOW RATE	TYPICAL R _{ca}
Natural Convection	2.4 °C/W
100 ft./min. (0.5m/s)	1.76 °C/W
200 ft./min. (1.0m/s)	1.17 °C/W
300 ft./min. (1.5m/s)	1.00 °C/W
400 ft./min. (2.0m/s)	0.83 °C/W

Example with heat sink:

What is the minimum airflow necessary for a PDF700S120-CMFD operating at 230VAC, an output current of 30A, and a maximum ambient temperature of 40°C with heat sink?

Solution:

Given: $V_{in}=230V_{ac}$, $V_o=12V_{dc}$, $I_o=30A$

Determine Power dissipation (P_d): $P_d=P_i-P_o= P_o(1-\eta)/\eta$, $P_d=12V \times 30A \times (1-0.875)/0.875=51.4Watts$

Determine airflow: Given: $P_d=51.4W$ and $T_a=40^\circ C$

Check above Power de-rating curve: Minimum airflow= 300 ft./min.

Verify:

Maximum temperature rise is $\Delta T=P_d \times R_{ca}=51.4 \times 1=51.4^\circ C$

Maximum case temperature is $T_c=T_a+\Delta T=40+51.4=91.4^\circ C < 95^\circ C$

Where:

The R_{ca} is thermal resistance from case to ambient environment

T_a is ambient temperature and T_c is case temperature



PDF700S CMFC(D/D-P), PDF700B CMFD(D-P) Series Application Note October V12

10. Packing Information

The packaging information of PDF700S-CMFC is as follows:

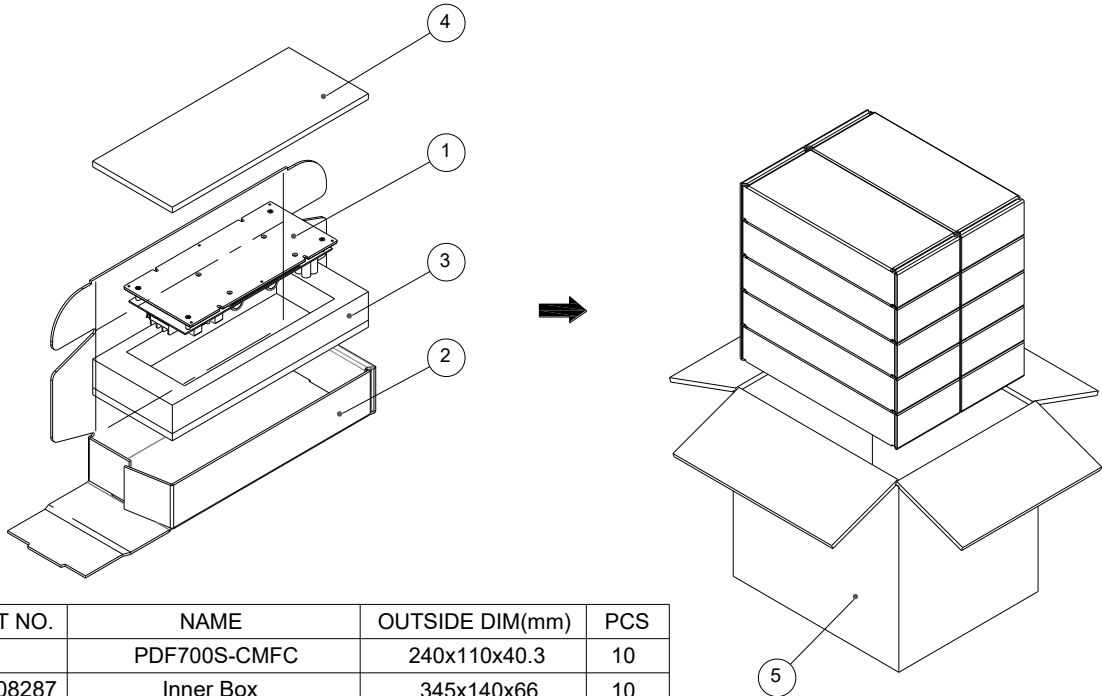

ITEM	PART NO.	NAME	OUTSIDE DIM(mm)	PCS
1		PDF700S-CMFC	240x110x40.3	10
2	G64208287	Inner Box	345x140x66	10
3	G64303200	Foam	320x130x50	10
4	G64303068	Foam	320x130x8	10
5	G64112275	No.99 Cardboard Box	366.6x303x360.6	1

Each Box Packaging 10 PCS Products
Gross weight Ref. 10.5 Kg



PDF700S CMFC(D/D-P), PDF700B CMFD(D-P) Series Application Note October V12

The PDF700S-CMFD, PDF700S-CMFD-P, PDF700B-CMFD and PDF700B-CMFD-P use the same packaging, taking PDF700S-CMFD series products as an example, the packaging information is as follows:

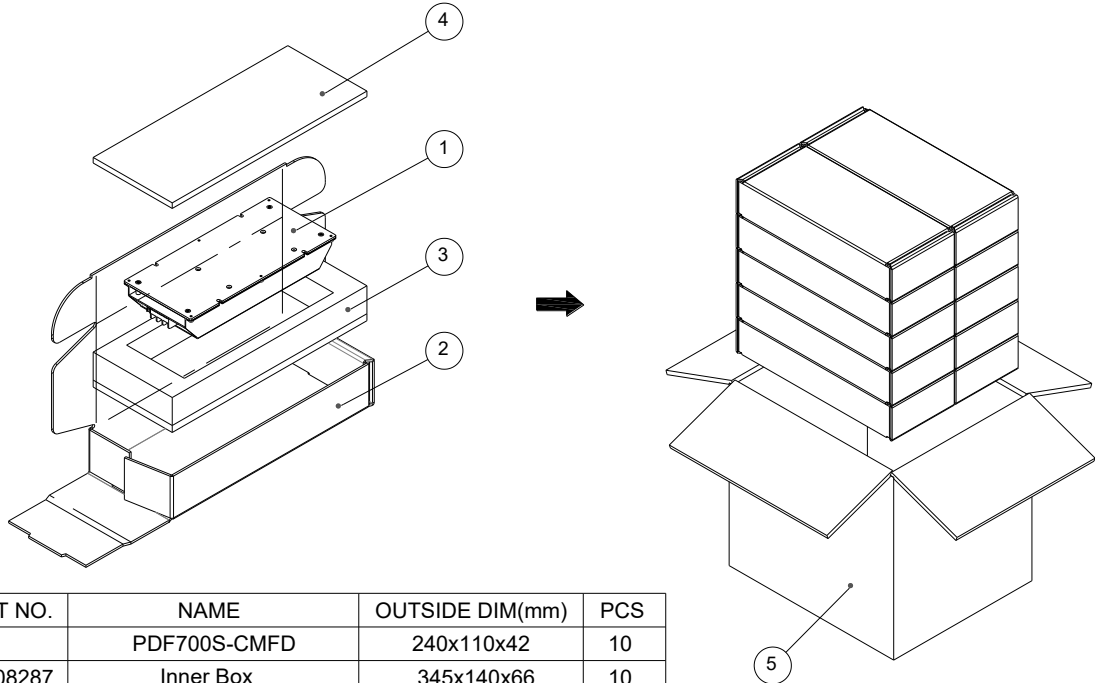

ITEM	PART NO.	NAME	OUTSIDE DIM(mm)	PCS
1		PDF700S-CMFD	240x110x42	10
2	G64208287	Inner Box	345x140x66	10
3	G64303200	Foam	320x130x50	10
4	G64303068	Foam	320x130x8	10
5	G64112275	No.99 Cardboard Box	366.6x303x360.6	1

Each Box Packaging 10 PCS Products
Gross weight Ref. 11.5 Kg

CINCON ELECTRONICS CO., LTD.

Headquarters:

14F, No.306, Sec.4, Hsin Yi Rd.
Taipei, Taiwan
Tel: 886-2-27086210
Fax: 886-2-27029852
E-mail: sales@cincon.com.tw
Web Site: <https://www.cincon.com>

Factory:

No. 8-1, Fu Kung Rd.
Fu Hsing Industrial Park
Fu Hsing Hsiang,
Chang Hua Hsien, Taiwan
Tel: 886-4-7690261
Fax: 886-4-7698031

Cincon North America:

1655 Mesa Verde Ave. Ste 180
Ventura, CA 93003
Tel: 805-639-3350
Fax: 805-639-4101
E-mail: info@cincon.com