



# LFM200M Series

## Application Note V11

### 200W AC-DC Power Supply with PFC

### LFM200M Series

### APPLICATION NOTE



**Approved By:**

Department	Approved By	Checked By	Written By
Research and Development Department	Ovid	Calvin	Jackie
Design Quality Department	Benny	JoJo	



# LFM200M Series

## Application Note V11

---

### Content

<b>1. INTRODUCTION</b>	<b>3</b>
<b>2. ELECTRICAL BLOCK DIAGRAM</b>	<b>3</b>
<b>3. MAIN FEATURES AND FUNCTIONS</b>	<b>4</b>
3.1 <i>Operating Temperature Range</i>	4
3.2 <i>Output Protection (Over Current Protection)</i>	4
<b>4. APPLICATIONS</b>	<b>4</b>
4.1 <i>Test Set-Up</i>	4
4.2 <i>Output Ripple and Noise Measurement</i>	4
4.3 <i>Installation Instruction</i>	5
4.4 <i>External Baseplate Cooling</i>	6
4.5 <i>EMI Test</i>	6
4.6 <i>Mating Connectors</i>	6
<b>5. PACKING INFORMATION</b>	<b>7</b>



# LFM200M Series

## Application Note V11

### 1. Introduction

This application note describes the features and functions of Cincon's LFM200M series power module. These are highly efficient, reliable, compact, high-power density, single output AC/DC power modules. The module is fully protected against short circuit and over-voltage conditions. Cincon's world class automated manufacturing methods, together with an extensive testing and qualification program, ensure that the LFM200M series power module is extremely reliable.

### 2. Electrical Block Diagram

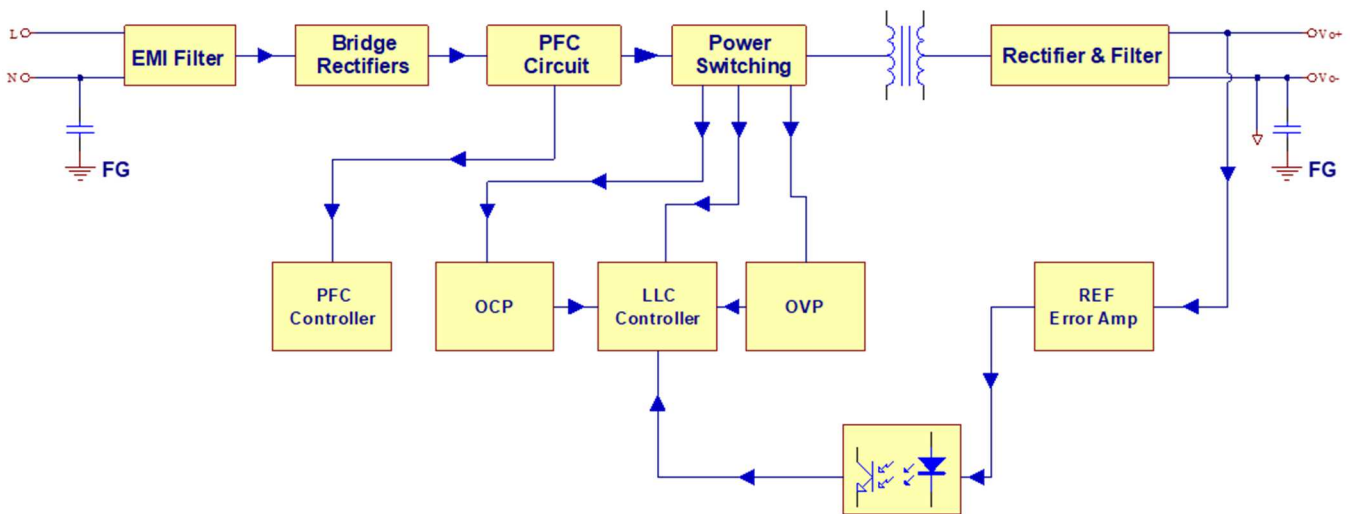



# LFM200M Series

## Application Note V11

### 3. Main Features and Functions

#### 3.1 Operating Temperature Range

The highly efficient design of Cincon's LFM200M series power modules has resulted in their ability to operate within ambient temperature environments from -40°C to 80°C. Due consideration must be given to the de-rating curves when ascertaining the maximum power that can be drawn from the module. The maximum power which can be drawn is influenced by a number of factors, such as:

- Input voltage range
- Permissible output load (per derating curve)
- Effective heat sinks

#### 3.2 Output Protection (Over Current Protection)

The power modules provide full continuous short-circuit protection. The unit will auto recover once the short circuit is removed. To provide protection in a fault condition, the unit is equipped with internal over-current protection. The unit will operate normally once the fault condition is removed. The power module will go to hiccup mode if the output current is set from 125% to 165% of rated current.

### 4. Applications

#### 4.1 Test Set-Up

The basic test set-up to measure parameters such as efficiency and load regulation is shown in Figure 1. When testing the Cincon's LFM200M series under any transient conditions, please ensure that the transient response of the source is sufficient to power the equipment under test. We can calculate the

- Efficiency
- Load regulation and line regulation

The value of efficiency is defined as:

$$\eta = \frac{V_o \times I_o}{V_{in} \times I_{in}} \times 100\%$$

Where:

- $V_o$  is output voltage,
- $I_o$  is output current,
- $V_{in}$  is input voltage,
- $I_{in}$  is input current

The value of load regulation is defined as:

$$\text{Load reg.} = \frac{V_1 - V_2}{V_2} \times 100\%$$

Where:

- $V_1$  is the output voltage at full load
- $V_2$  is the output voltage at 10% load

The value of line regulation is defined as:

$$\text{Line reg.} = \frac{V_{HL} - V_{LL}}{V_{LL}} \times 100\%$$

Where:

- $V_{HL}$  is the output voltage of maximum input voltage at full load
- $V_{LL}$  is the output voltage of minimum input voltage at full load

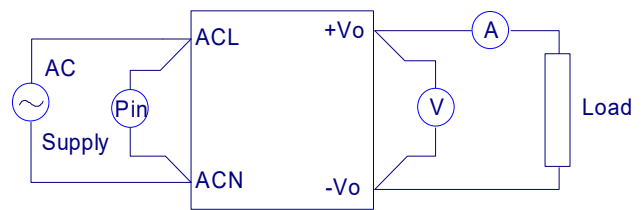

Figure 1. LFM200M Series Test Setup

#### 4.2 Output Ripple and Noise Measurement

The test set-up for noise and ripple measurements is shown in Figure 2. Measured method:

Add a  $C_2=0.1\mu\text{F}$  ceramic capacitor and a  $C_1=10\mu\text{F}$  electrolytic capacitor to output at 20 MHz Band Width.

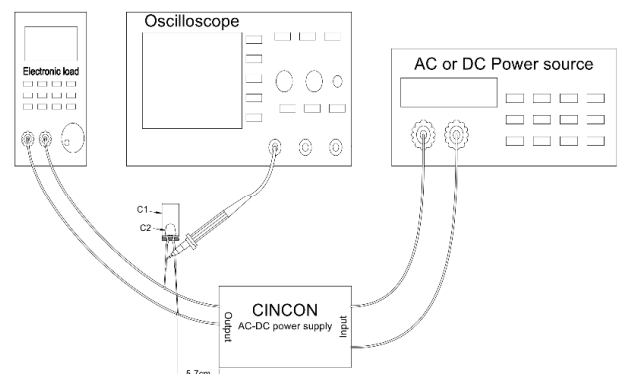

Figure 2. Output Voltage Ripple and Noise Measurement Set-Up



# LFM200M Series

## Application Note V11

### 4.3 Installation Instruction

The LFM200M series provide the baseplate cooling for customer to increasing heat dissipation. Please refer to the following figure for installation.

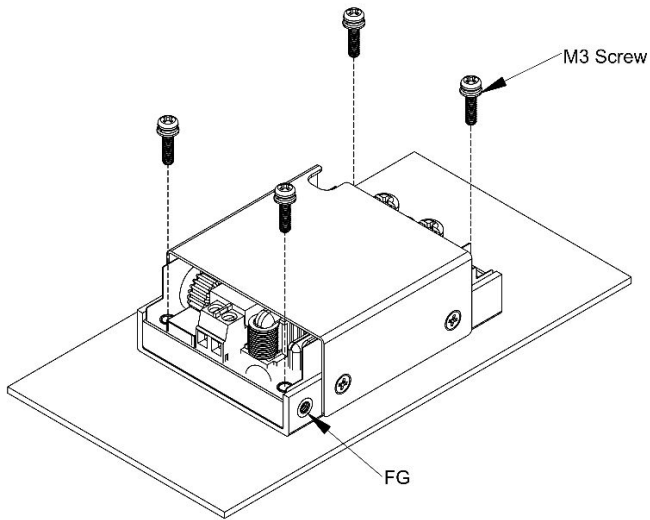

**LFM200MXXXC installation diagram**

Note:

M3 screw head and washer diameter shall not exceed 5.5mm. M3 torque is 4 kgf-cm max.

Please allow 4mm side clearance from the components and all side of the PCB. Allow 5mm clearance above the highest parts on the PCB. Be especially careful to allow 5mm between the solder side of the PCB and the mounting surface. If the clearances are not sufficient the specifications for isolation and withstand will not be valid.

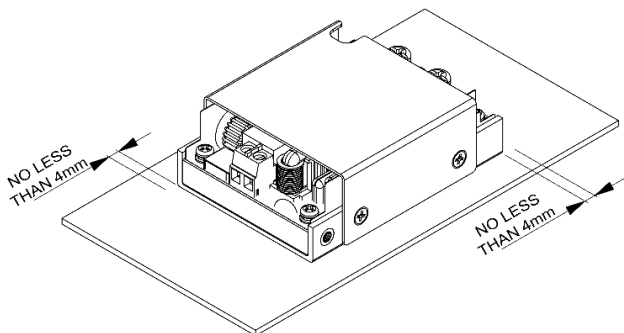

**LFM200MXXXC installation diagram**

The LFM200M FG should be connected to the earth (ground) terminal of the apparatus for Figure 3 or can be used in the end-equipment connected to the earth (ground) terminal of the apparatus for Figure 4. If not the conducted noise and output noise will increase.

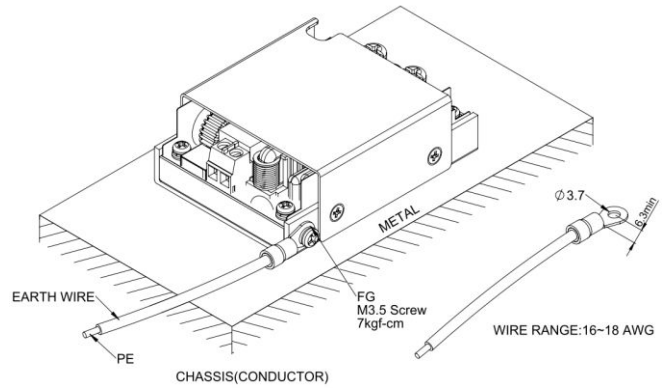

**Figure 3**

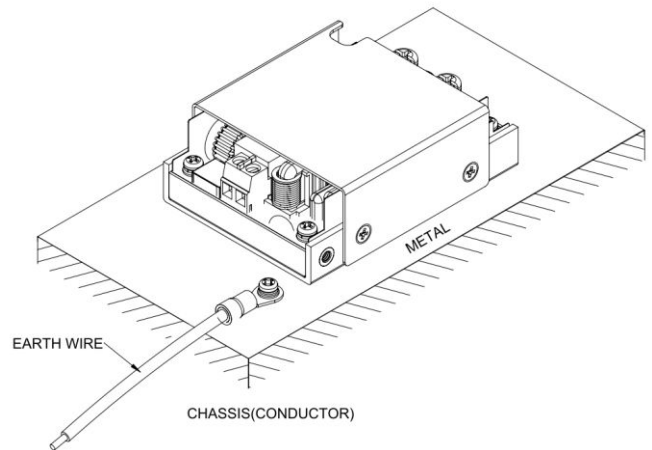

**Figure 4**



# LFM200M Series

## Application Note V11

### 4.4 External Baseplate Cooling

The LFM200M series provide the baseplate cooling for customer to increasing heat dissipation. For example, adding a 177.8mmx177.8mmx2mm heatsink at the bottom of LFM200M, between the heatsink and LFM200M with thermal grease better than 0.83 W/m.K or thermal pad (PMP-P-400) to help heating ability. If customer choose the other heatsinks. LFM200M make sure of the heatsink  $R_{ac}=1.5^{\circ}\text{C}/\text{W}$  or better and  $T_c$  point under  $90^{\circ}\text{C}$ .

Please refer to the following figure for installation. When the LFM200M series uses an external baseplate cooling solution, it can be used at 180W. Please refer to the power derating curve in the specification.

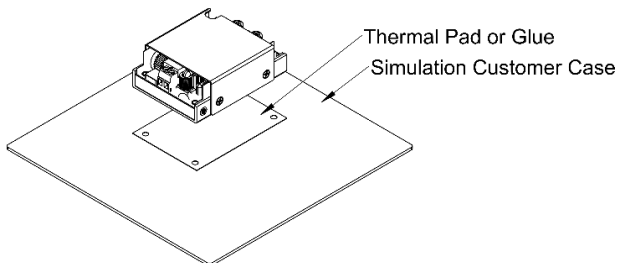
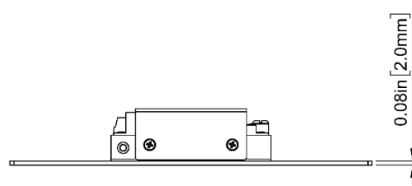
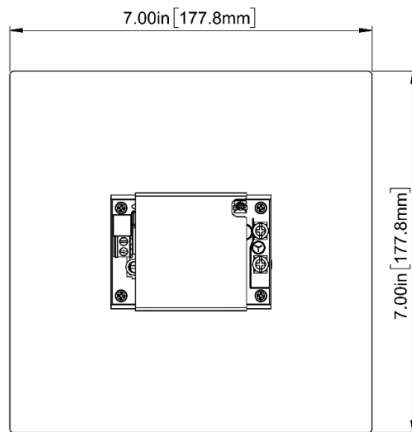

Thermal Pad: 78.6x55.9x0.25mm (G61236RC304)

### 4.5 EMI Test

The LFM200M series Conductive EMI meets EN55011, FCC Part 18 Class B when test condition is Class I.

### 4.6 Mating Connectors

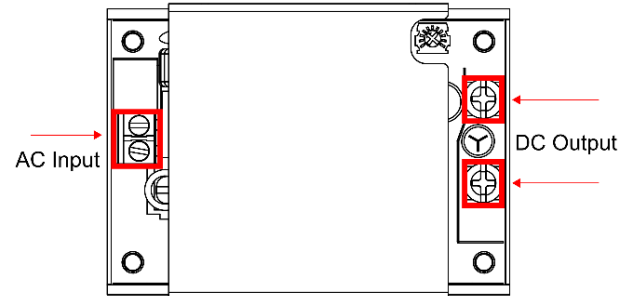

LFM200MXXXC installation diagram

AC Input Connector(CN1):ECE ETB22

Pin	Function	Mating Wire Range
1	ACL	14~18 AWG
2	ACN	

DC Output Connector:KANG YANG PCB-58M4

Function	The screw locked torque
+Vo	M4 7kgf-cm
-Vo	



# LFM200M Series

## Application Note V11

### 5. Packing Information

The packing information for LFM200MXXXC series is showing as follows:

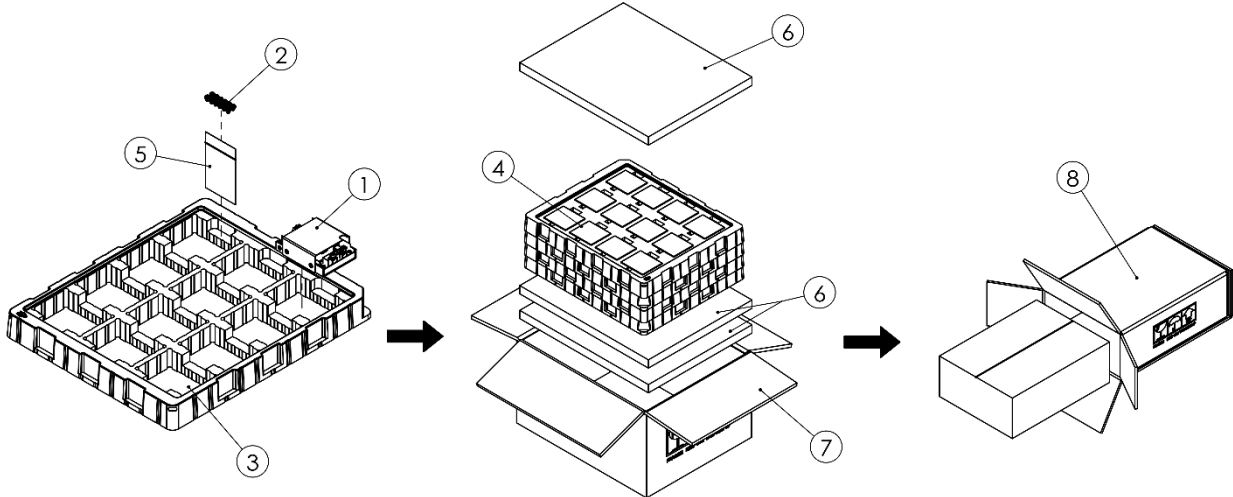

ITEM	PART NO.	NAME	OUTSIDE DIM(mm)	PCS
1	-	LFM200MXXXC Product	78.6x57.9x25.4	48
2	G75V2200000	Screw	M3.5x0.6	48
3	G64G20152	Antistatic Plastic blister	338.4x283.4x34.2	4
4	G64G20151	Antistatic Plastic blister	340x285x35	4
5	GT4101	Zipper Bag	70x50x0.04	4
6	G64301087	Antistatic Foma	360x290x20	3
7	G64211308	No.114 Inner Cardboard Box	364x294x200	1
8	G64114293	No.114 Cardboard Box	400x320x225	1

Each Box Packaging 48 PCS Products  
Gross weight Ref. 11 Kg

#### Headquarters:

14F, No.306, Sec.4, Hsin Yi Rd.  
Taipei, Taiwan  
Tel: 886-2-27086210  
Fax: 886-2-27029852  
E-mail: [sales@cincon.com](mailto:sales@cincon.com)  
Web Site: <https://www.cincon.com>

#### CINCON ELECTRONICS CO., LTD.

#### Factory:

No. 8-1, Fu Kung Rd.  
Fu Hsing Industrial Park  
Fu Hsing Hsiang,  
Chang Hua Hsien, Taiwan  
Tel: 886-4-7690261  
Fax: 886-4-7698031

#### Cincon North America:

1655 Mesa Verde Ave. Ste 180  
Ventura, CA 93003  
Tel: 805-639-3350  
Fax: 805-639-4101  
E-mail: [info@cincon.com](mailto:info@cincon.com)