



FM SERIES 30 AMP FILTER MODULE



FEATURES

- * Compact Size 2.28"x1.45"
- * Quarter-Brick Size
- * Six-Sided Shield Metal Case
- * PCB Mount
- * 30A Filter Module
- * 80VDC Input Voltage Maximum
- * Suitable for EN50121-3-2:2015 Output Specification
- * Fire & Smoke Meets EN45545-2



MODEL NUMBER	INPUT VOLTAGE	INPUT SURGE VOLTAGE	RATED CURRENT (INPUT to OUTPUT)	DC RESISTANCE (+Vin to +Vo)	DC RESISTANCE (-Vin to -Vo)
FM30R080P	80 VDC max.	100 VDC max.	30 A max.	3.0 mΩ typ.	3.0 mΩ typ.

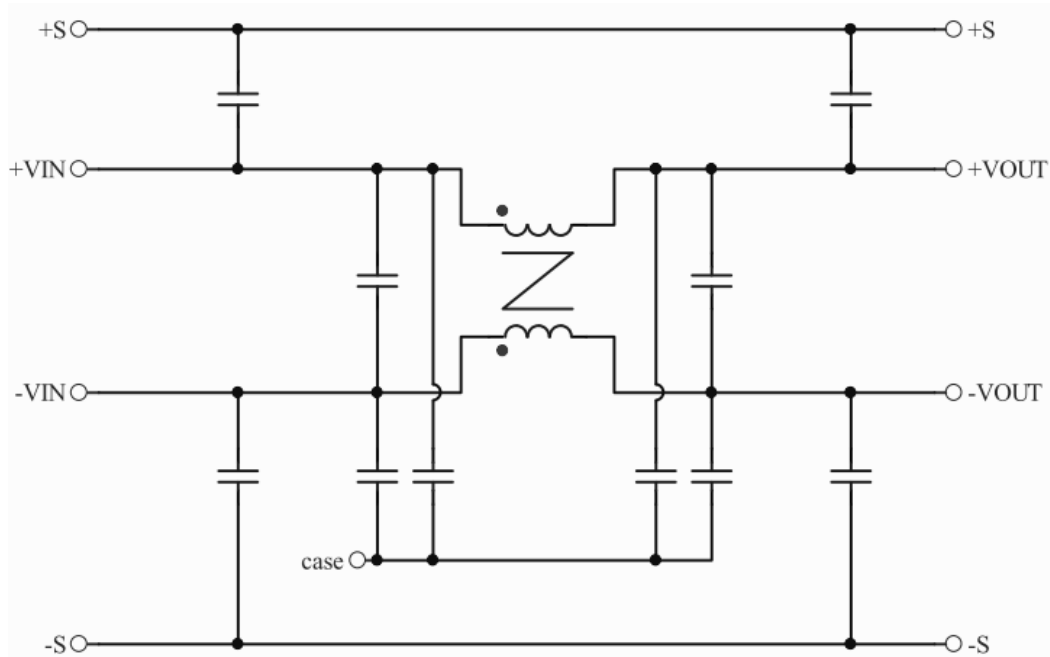

Schematic for FM30R080P Module

SPECIFICATIONS

All Specifications Typical At Nominal Line, Full Load, and 25°C Unless Otherwise Noted

INPUT SPECIFICATIONS:

Input Voltage Range 80Vdc max.
 Input Surge Voltage 100Vdc/1s
 Input Rated Current (note 1) 30A max.

NOTE:

1. Maximum case temperature under any operating condition should not exceed 110°C.

GENERAL SPECIFICATIONS:

Isolation Voltage Input/Case/Output/Case 1000Vdc min.
 Isolation Resistance..... 10⁸ohm min.
 DC Resistance See Table
 Operating Case Temperature Range (note1) -40°C to +110°C
 Storage Temperature Range -55°C to +125°C
 Dimensions 2.28x1.45x0.50inches (57.9x36.8x12.7mm)
 Case Materials Aluminum with Non-Conducted Base
 Weight 60g

Typical Derating Curve

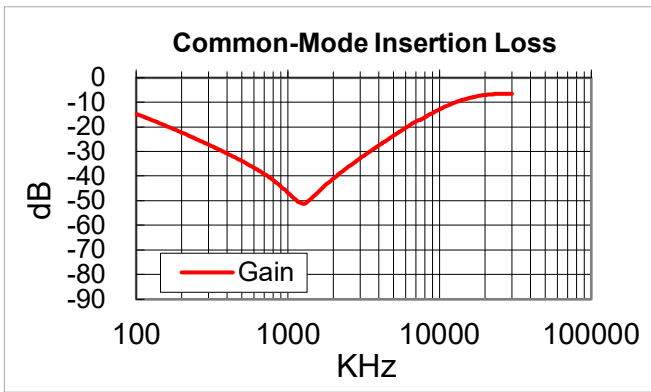
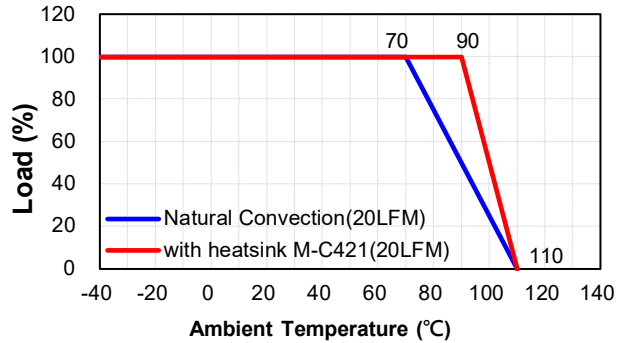

Typical Common-mode Loss for FM30R080P

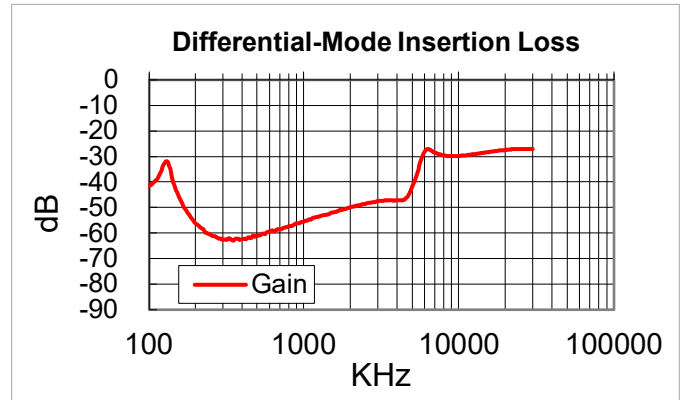

Typical Differential-mode Loss for FM30R080P

All Dimensions In Inches[mm]

Tolerance Inches:x.xx= ±0.02, x.xxx= ±0.010

Millimeters:x.x= ±0.5, x.xx=±0.25

BOTTOM VIEW

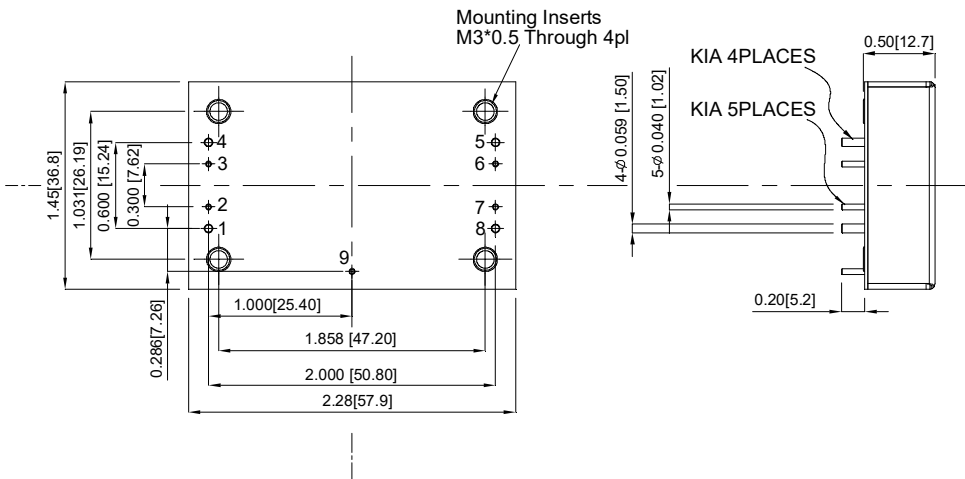

PIN CONNECTION	
PIN	Function
1	+V Input
2,7	+Sense
3,6	-Sense
4	-V Input
5	-V Output
8	+V Output
9	Case