

## HBC400 Series

E-Mobility 4kW DC/DC Isolated Bidirectional Power Converter Module



### Product Overview

HBC400 is a series of rugged, highly efficient, 4kW liquid-cooled, bidirectional DC/DC power converters that convert 220-440V high side DC input voltage into a 12Vdc or 24Vdc isolated low side voltage, supporting 12/24V battery configurations.

HBC400 power converters incorporate a digitally controlled Dual Active Bridge topology with synchronous output rectification to achieve high efficiency and EMI performance. The compact thermally optimized IP67 ingress rated enclosure provides a high degree of shock and vibration resistance, suitable for deployment within harsh environments.

Bi-directional conversion capability:

- **Buck-Mode Direction:** Converts the high side input voltage (220-440Vdc) into a 12V/24V low side output.
- **Boost-Mode Direction:** Converts low side input of 12V/24V into the high side output voltage (220-440Vdc).

The comprehensive SAE J1939 compliant CAN digital interface, standard hardware signals including HVIL (High Voltage Interlock Loop) and the bidirectional conversion features make this series suitable for adaptation in industrial, agriculture, marine, mining and other E-mobility applications.

### Features

- Bidirectional operation
- Wide high-side Input Voltage range: 220V to 440Vdc via robust Amphenol Powerlok series connector with integrated HVIL contacts
- 12Vdc and 24Vdc models, supporting 12/24V battery configurations
- CAN 2.0B SAE J1939 compliant digital communications interface for monitoring, control and configuration capability
- High efficiency; up to 96%
- Input to output safety isolation
- Liquid cooled, IP67 rugged enclosure: 359 (L) x 205 (W) x 78 (H) suitable in harsh environments
- Over-Current, Short-Circuit and Over-Temperature fault protection
- E-Mark Pending

### OPERATIONAL CHARACTERISTICS

PARAMETER	MIN	TYP	MAX	UNITS
Operating Temperature	-40		+85	°C
Storage Temperature	-40		+95	°C

BUCK MODE				
Parameter	Min.	Typ.	Max.	Units
Input Voltage Range	220	350	450	Vdc
Input Voltage Range at 100% Load	310		390	Vdc
Turn-on Voltage	210	215	220	Vdc
Turn-off Voltage	200	205	210	Vdc
Input Current			13	Adc
Input Over-Voltage Protection	455		465	Vdc
Efficiency	96			%

BOOST MODE				
Parameter	Min.	Typ.	Max.	Units
Input Voltage Range	9	14	16	Vdc
Input Voltage Range at 100% Load	12		16	Vdc
Turn-on Voltage	8		9	Vdc
Turn-off Voltage	8		9	Vdc
Efficiency	96			%

ORDERING GUIDE				
Model	Input Voltage	Output Voltage	Output Current	Max. Output
400S12.4KOHBC	220-440Vdc	8-16Vdc	300A	4kW
400S24.4KOHBC		16-32Vdc	150A	

### Mechanical Specifications

MECHANICAL	DESCRIPTION	UNIT
Dimensions	359 (L) x 205 (W) x 78 (H)	mm
Weight	6	kg
Enclosure	Aluminum, anodized IP67	

#### OUTLINE DRAWING (TBD)

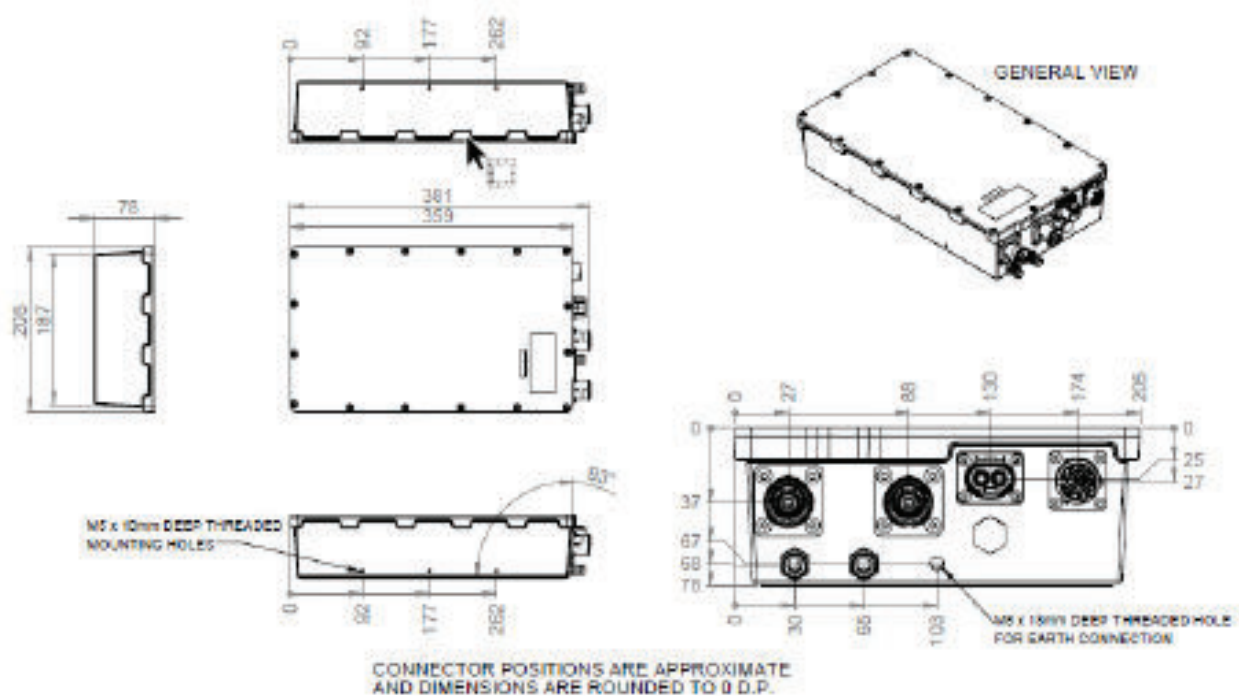

#### MECHANICAL NOTES:

- THIS DRAWING IS A GRAPHICAL REPRESENTATION OF THE POWER MODULE SHOWN FOR ILLUSTRATION PURPOSED. NOT ALL FINE DETAILS ARE SHOWN. PLEASE CONTACT CALEX FOR 3D MODEL OR F COMPONENT DRAWINGS FOR DETAILED DIMENSIONS AND MATERIAL INFORMATION
- REFERENCE FILE: 210614\_DRG1143-1A DC DC CONVERTER ASSEMBLY
- DIMENSIONS: MM, MATERIAL: 0.80MM HOT DIPPED GALVANIZED STEEL, GRADE G60 MINIMUM SPANGLE FINISHED WITH A CR(6+) FREE CORROSION RESISTANT COATING
- DIMENSIONS OF CONNECTOR LOCATIONS SHOWN TO CENTRE OF CONNECTORS
- HOSE TAILS FOR COOLING CIRCUIT TO FIT 12MM INNER DIAMETER HOSE FOR BOTH INLET AND OUTLET FLOW
- CONNECTOR LOCATIONS ARE APPROXIMATE
- DIMENSIONS ARE ROUNDED TO 0 DP