

ARTESYN SIL05E Series

Non-Isolated DC-DC Converters

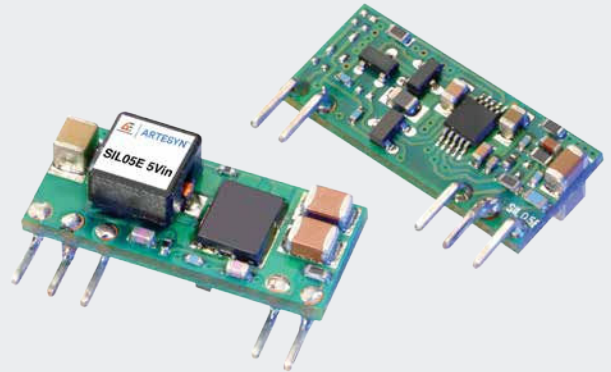

Advanced Energy's Artesyn SIL05E series are non-isolated dc-dc converters packaged in a single-in-line footprint giving designers a cost effective solution for conversion from a 3.3 - 5 Vin source. The SIL05E has a wide input range (3.0 - 5.5 Vdc) and offers a wide 0.75 - 3.63 Vdc output voltage range with a 5 A load, which allows for maximum design flexibility and a pathway for future upgrades. The SIL05E is designed for applications that include distributed power, workstations, optical network and wireless applications. Implemented using state of the art automated manufacturing techniques, the SIL05E offers compact size and efficiencies of up to 94%.

SPECIAL FEATURES

- 5 A current rating
- Input voltage range:
3.0 - 5.5 Vdc
- Output voltage range:
0.75 - 3.63 V
- Ultra-high efficiency:
94% @ 5 Vin and 3.3 Vout
- Extremely low internal power dissipation
- Minimal thermal design concerns
- Designed in reliability:
MTBF of >9 million hours per
Telcordia SR-322
- Ideal solution where board space is
at a premium or tighter card pitch
is required

- Industry standard footprint
- Available RoHS compliant
- Two year warranty

SAFETY

- UL, cUL CAN/GSA 22.2 No.
E174104
UL60950 File No. E174104
- TÜV Product Service (EN60950)
Certificate No. B 03 10 38572
- CB report and certificate to
DE3-51686M1

DATA SHEET

Total Power:

Up to 18 W

Input Voltage:

3.0 - 5.5 Vac

of Outputs:

Single



ELECTRICAL SPECIFICATIONS

Input	
Input range	3.0 - 5.5 Vdc
No Load Input Current	150mA
Input current (max.)	3.9 A max. @ Io max. and Vout = 3.3 V
Input reflected ripple	40 mA rms
Remote ON/OFF	See Note 1
Start-up time	
Output	
Voltage adjustability	0.75 - 3.63 Vdc
Setpoint accuracy	±0.4%.
Line regulation	±1.0%
Load regulation	±1.0%
Minimum load	0A
Overshoot/undershoot	None
Ripple and noise 5 Hz to 20 MHz	75 mV pk-pk 25 mV rms
Temperature co-efficient	±0.01%/°C
Transient response	60 mV max. deviation 50 µs recovery within 1%

Note: All specifications are typical at nominal input, full load at 25 °C unless otherwise stated.

GENERAL SPECIFICATIONS

Efficiency	94%
Insulation voltage	Non-isolated
Switching frequency Fixed	300 kHz typical
Approvals and standards	EN60950 UL/cUL60950
Material flammability	UL94V-0
Dimensions L x W x H	22.90 x 7.09 x 10.21 mm 0.902 x 0.279 x 0.402 inches
Weight	2.5 g (0.09 oz)
Coplanarity	100 µm
MTBF Telcordia SR-332	9,009,000 hours

ENVIRONMENTAL SPECIFICATIONS

Operating ambient temperature	-40 ° to 85 °C
Non-operating temperature	-40 ° to 125 °C
Short-circuit	Continuous
Thermal	Automatic recovery

EMC CHARACTERISTICS

Electrostatic discharge	EN61000-4-2, IEC801-2
Conducted immunity	EN61000-4-6
Radiated immunity	EN61000-4-3

ORDERING INFORMATION

Model Number ^(3,4)	Output Power (Max.)	Input Voltage	Output Voltage	Output Current (Min.)	Output Current (Max.)	Efficiency (Typical)	Regulation	
							Line	Load
SIL05E-05W3V3-VJ	18.15 W	3.0 - 5.5 V	0.75 - 3.63 V	0 A	5 A	94%	±1.0%	±1.0%

PART NUMBER SYSTEM WITH OPTIONS

Product Family	Rated Output Current	Performance	Input Voltage	Type of Output	Output Voltage	Mounting/Packaging Options
SIL	05	E	05	W	3V3	VJ
SIL = Single In Line	05 = 5 Amps	E = Enhanced Performance	05 = 3.0 - 5.5 Vdc	W = Wide	0.75 - 3.63 Vdc	V = Vertical H = Horizontal J = Pb-free (RoHS 6/6 compliant)

OUTPUT VOLTAGE ADJUSTMENT

The ultra-wide output voltage trim range offers major advantages to users who select the SIL05E-05W3V3. It is no longer necessary to purchase a variety of modules in order to cover different output voltages. The output voltage can be trimmed in a range of 0.75 to 3.63 Vdc.

When the SIL05E-05W3V3 converter leaves the factory, the output has been adjusted to the default voltage of 0.75 V.

- When $V_{in} > 4.5$ V, then V_{out} can be adjusted from 0.75 - 3.63 Vdc
- When $V_{in} < 4.5$ V, then V_{out} can be adjusted from 0.75 - 2.75 Vdc

Notes:

1. The SIL05E features a 'Negative Logic' Remote ON/OFF operation. If not using the Remote ON/OFF pin, leave the pin open (the converter will be on). The Remote ON/OFF pin is referenced to ground. The following conditions apply for the SIL05E:

Configuration

- Remote pin open circuit
- Remot pin pulled low
- Remote pinpulled high [$V_{on/off} > 2.5$ V]

Converter Operation

- Unit is ON
- Unit is ON
- Unit is OFF

A 'Positive Logic' Remote ON/OFF version is also possible with this converter. To order please use part number SIL05E-05W3V3-VRJ.

2. Full derating curves available in both the Longform (Technical Reference) and Application Note.
3. For horizontal mounting option, please consult factory for details.
4. NOTICE: Some models do not support all options. Please contact your local Advanced Energy's Artesyn representative or use the on-line model number search tool at <http://www.artesyn.com> to find a suitable alternative.

MECHANICAL DRAWINGS

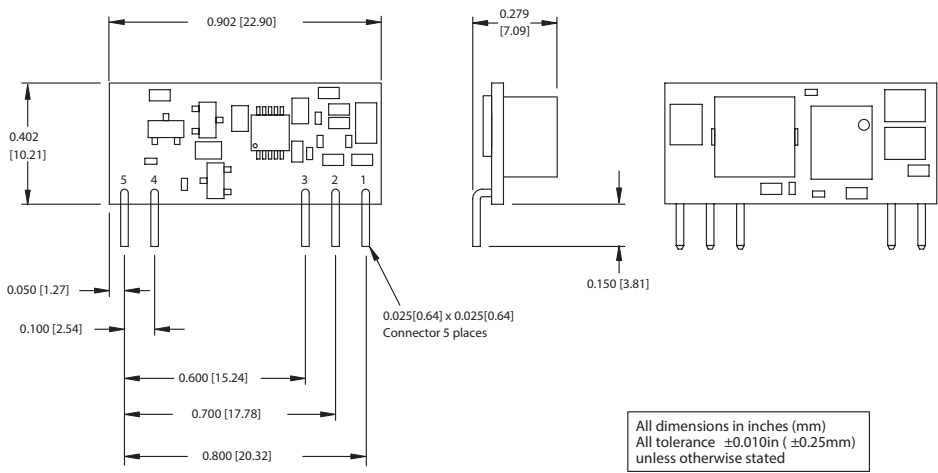

Pin Assignments	
Pin No.	Function
1	Vout
2	Trim
3	Ground
4	Vin
5	Remote ON/OFF



For international contact information,
visit advancedenergy.com.

powersales@aei.com (Sales Support)
productsupport.ep@aei.com (Technical Support)
+1 888 412 7832

ABOUT ADVANCED ENERGY

Advanced Energy (AE) has devoted more than three decades to perfecting power for its global customers. AE designs and manufactures highly engineered, precision power conversion, measurement and control solutions for mission-critical applications and processes.

Our products enable customer innovation in complex applications for a wide range of industries including semiconductor equipment, industrial, manufacturing, telecommunications, data center computing, and medical. With deep applications know-how and responsive service and support across the globe, we build collaborative partnerships to meet rapid technological developments, propel growth for our customers, and innovate the future of power.

PRECISION | POWER | PERFORMANCE

Specifications are subject to change without notice. Not responsible for errors or omissions. ©2021 Advanced Energy Industries, Inc. All rights reserved. Advanced Energy®, AE® and Artesyn™ are U.S. trademarks of Advanced Energy Industries, Inc.