

Typical Features

- ◆ Fixed input voltage, Isolated & unregulated output, Output power 2W
- ◆ High Efficiency up to 86%
- ◆ Small compact SIP packing
- ◆ No external component required
- ◆ Isolation Voltage 3000VDC
- ◆ Operating Temperature: -40°C~+85°C
- ◆ Plastic Case, meet UL94 V-0 standard



Test Condition: Unless otherwise specified, data in the datasheet should be tested under the conditions of inputting nominal voltage, pure resistance rated load and Ta=25°C

Application Field

It could be widely used for instrument, communication, pure digital circuit, general low frequency analog circuit, relay drive circuit, data exchange circuit, etc.

Typical Product List

Model	Input Voltage Range (VDC)		Output Voltage/ Current (Vo/Io)		Input Current(mA) Nominal Voltage		Max. Capacitive Load	Ripple & Noise (Max.)	Efficiency (%)full load, input nominal voltage	
	Nominal	Range	Voltage (VDC)	Current(mA) MAX./Min.	Full load Typ.	No Load Typ.	uF	mVp-p	Min.	Typ.
FN2-05S3V3C3N	5	4.5 - 5.5	3.3	600	533	50	470	150	68	72
FN2-05S05C3N			5	400	474	24	470	150	76	80
FN2-05S09C3N			9	220	513	50	470	150	80	84
FN2-05S12C3N			12	167	513	50	470	150	79	83
FN2-05S15C3N			15	133	460	26	470	150	78	82
FN2-05S24C3N			24	83	506	50	470	150	80	84
FN2-12S05C3N	12	10.8 - 13.2	5	400	208	20	470	150	78	82
FN2-12S09C3N			9	220	183	20	470	150	77	81
FN2-12S12C3N			12	167	183	20	470	150	80	84
FN2-12S15C3N			15	133	187	20	470	150	81	85
FN2-12S24C3N			24	83	186	20	470	150	82	84
FN2-24S3V3C3N	24	21.6 - 26.4	3.3	600	113	10	470	150	83	87
FN2-24S05C3N			5	400	100	6	470	150	76	80
FN2-24S09C3N			9	220	95	7	470	150	82	86
FN2-24S12C3N			12	167	96	6	470	150	80	84



FN2-24S15C3N		15	133	105	10	470	150	82	86
FN2-24S24C3N		24	83	97	10	470	150	82	86

Note: In order to ensure the converter can work reliably with high efficiency, the minimum load should not less than 10% rated load when it is used. If the needed power is indeed small, please parallel a resistor at the output side, the resistance recommended equal to 10% nominal power.

Input Specifications

Item	Working Conditions	Min.	Typ.	Max.	Unit
Input Overshoot Voltage (1Second.max.)	5Vdc Input	-0.7	--	9	VDC
	9Vdc Input	-0.7	--	15	
	24Vdc Input	-0.7	--	30	
Input Filter	Capacitor Filter				

Output Specifications

Item	Working Conditions	Min.	Typ.	Max.	Unit	
Output Power		0.2	--	2	W	
Output Voltage Accuracy	Nominal input, Full load	--	±2	±5	%	
Load Regulation	10% ~ 100% nominal load	3.3Vdc output	--	--		20
		Other output	--	--		15
Line Voltage Regulation	Input Voltage Change±1%	3.3Vdc output	--	--		±1.5
		Other output	--	--	±1.2	
Ripple & Noise①	Nominal input, full load, 20MHZ bandwidth, other output	--	100	150	mVp-p	
Temperature Drift Coefficient	100% Full Load	--	--	±0.03	%/°C	
Output Short Circuit Protection	Continuous short-circuit protection, self-recovery					

NOTE:①Ripple & Noise tested by twisted-pair method;

General Specifications

Switching Frequency	Typical	100KHz (Typ.)
Operating Temperature	Refer to Temperature Derating Curve	-40°C ~ +85°C
Storage Temperature		-55°C ~ +125°C
Shell temperature rise during work	Within Temperature Derating Curve	25°C(Typ.)
Relative Humidity	No condensing	5%~95%
Case Material		Black flame-retardant heat-resistant Plastic(UL94 V-0)
Pin resistance to welding temperature	Distance between solder joint and shell 1.5mm, 10s	300°C MAX
Isolation Voltage	Test 1 minute, leakage current<	3000Vdc

	0.5mA	
Isolation Capacitor	Input/Output,100KHz/0.1V	20 pF (Typ.)
MTBF	MIL-HDBK-217F@25°C	35X10 ⁵ Hrs
Product Weight		2.5g (Typ.)
Packing	Tube(525*18*10mm)	25PCS
	Box(542*110*155mm)	2000PCS(Total 80tubes)

Packing Dimension

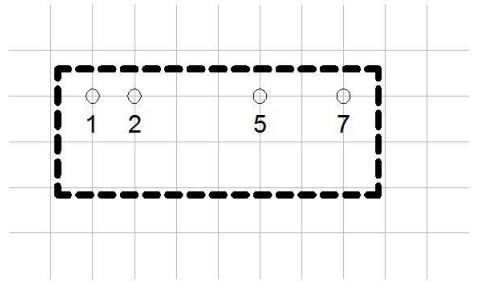
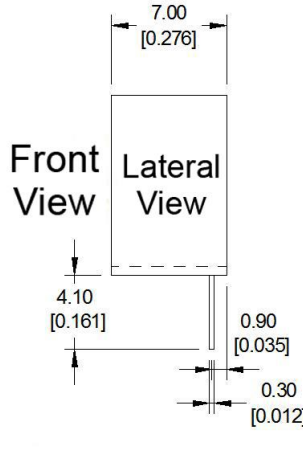
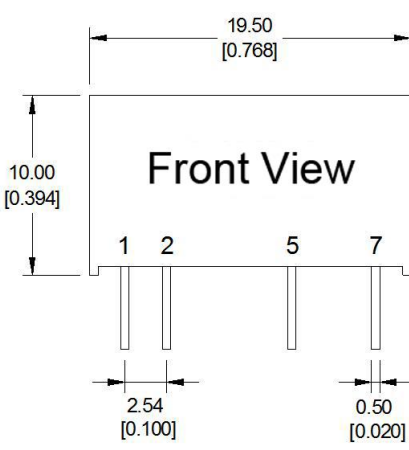

Print board vertical view
Grid: 2.54mm(0.1inch)

Unit: mm
General tolerance: 0.xx±0.1(0.xx±0.004)
Pin section tolerances: ±0.25(0.xx±0.01)

Packing Code	L x W x H	
C	19.50×7.00 × 10.00mm	0.768 × 0.276 × 0.394inch

Pin Function

Pin Function	1	2	3, 4	5	6	7
Single(S)	+Vin	GND	NP	-Vo	NP	+Vo

Note: if the definition of pin is not in accordance with the model selection manual, please refer to the label on actual item.

Ripple & Noise Test: (Twisted Pair Method 20MHZ bandwidth)

Test Method:

a. 12# twisted pair to connect, Oscilloscope bandwidth set as 20MHz, 100M bandwidth probe, terminated with 0.1uF polypropylene capacitor and 10uF high frequency low resistance electrolytic capacitor in parallel, oscilloscope set as Sample pattern.

b. Input terminal connect to power supply, output terminal connect to electronic load through jig plate, Use 30cm±2 cm sampling line, Power line selected from corresponding diameter wire with insulation according to the flow of output current.

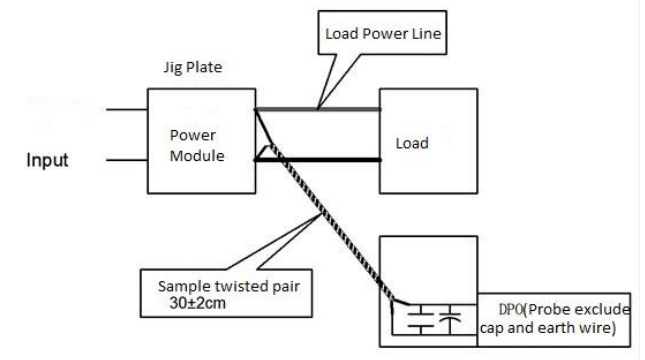

Temperature Curve

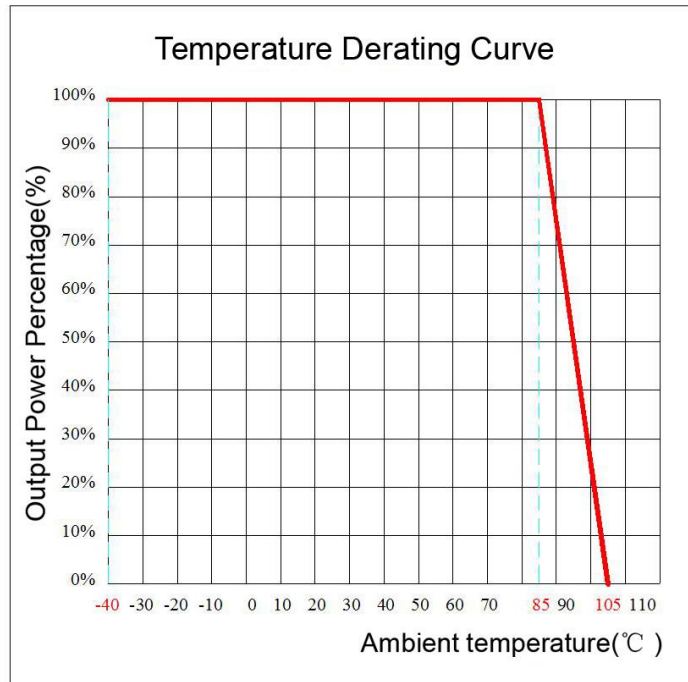

Design and Application Circuit Recommended

1. Output load requirements

- a. In order to ensure the converter can work reliably with high efficiency, the minimum load should not less than 10% rated load when it is used. If the needed power is indeed small, please parallel a resistor at the output side, the resistance equal to 10% nominal load.
- b. The maximum capacitive load is tested under nominal input full load, and cannot exceed the maximum capacitive load of output terminal under operation, otherwise it will cause it difficult to start up and damage the product.

2. Recommended circuit

In order to ensure the input/output ripple and noise decreased, capacitor filter net could be connected to input and output terminal, application circuit as below photo 1; choosing suitable filter capacitor is very important, start-up problems may be caused by too large capacitance. To ensure the modules running safely and reliably, the recommended capacitive load values as shown in Table 1. (But for the actual output power of application circuit is less than 0.5W, suggest not to connect external capacitor)

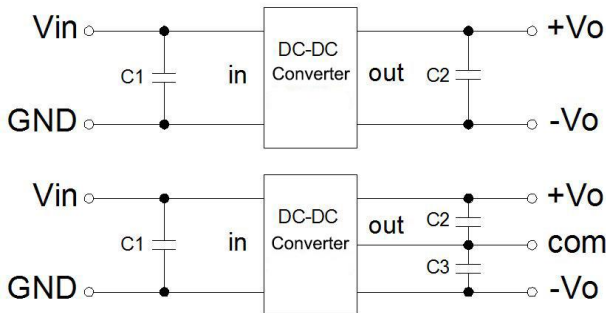

Recommended capacitive load value (Table 1)

Vin (Vdc)	C1 (μF)	Vout (Vdc)	C2 (μF)	Vout (Vdc)	C2,C3 (μF)
3.3/5	4.7	3.3/5	10	±3.3/±5	4.7
12	2.2	9	4.7	±9	2.2
15	1	12	2.2	±12	1
24	1	15	1	±15	0.47
--	--	24	0.47	±24	0.22



3. Output regulated voltage and over voltage protection circuit

The simplest device to protect output regulated voltage, over voltage and over current is to cascade a linear regulator with overheat protection at input or output terminal, and connect a capacitor filter net(see below picture), filter capacitive value recommended see table 1, Linear regulator is chosen according to the actual voltage, current needed in working, or choose our NW series products.

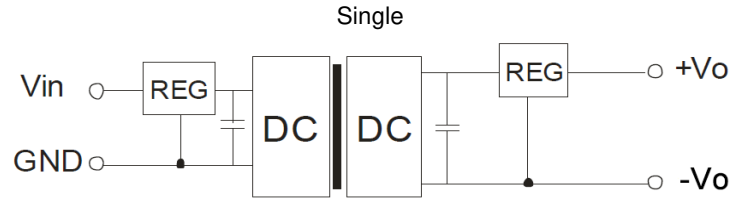

Note:

1. This product cannot be used in parallel, and do not support hot-plugging;
2. If the product works below the minimum required load, it cannot guarantee that the product performance meets all performance indicators in this manual;
3. All index testing methods in this datasheet are based on our Company's corporate standards
4. The product specification may be changed at any time without prior notice.