



- Compact high density design with outstanding thermal performance.
- Operation to 600W; mounted to cooling plate at +85°C max.
- 12V, 24V and 48V Output
- -5%; +15% output adjustment.
- IP67 sealed “weatherproof” case.
- Overall dimensions (w/o connectors)
233.7 x 128.1 x 40.2 mm
9.20" x 5.04" x 1.58".
- Main DC output via studs.
- AC input and signals via separate circular connectors.
- High efficiency of 93.5% at 100% load.
- Droop characteristic current sharing.
- True zero load operation of Main (V1) output; no minimum load required.
- Universal AC input with active PFC; meets EN61000-3-2 Class A limits.
- MTBF in excess of 150K hours to MIL217F-3, Ground, Fixed, uncontrolled moderate, Temp; +40°C (target).
- RoHS3 Directive 2015/863 compliant
- Active inrush protection.
- IEC/EN/UL/CSA 60950-1; Edition 2.
- Migration path to IEC/EN/UL CSA62368-1.
- CE Marking to LVD 2014/35/EU.
- Extended standard warranty.

Product Overview

The 600-Watt IHC is a new series of AC-DC harsh environment industrial power supplies. The IHC series is aimed at ruggedized and special applications that require operation in extreme industrial environmental conditions such as, elevators, external road signs, electrolysis equipment, food processing and other outdoor applications.

Intended for ease of connection, the I/O and signal connectors are ruggedized and the product enclosure is sealed (IP67).

The assembly can be baseplate mounted to a thermal (cold) plate or natural convection, conduction cooled to allow operation over a wide -40°C to +85°C baseplate operating temperature range.

The output overload protection employs a constant current characteristic that allows use with high transient capacitive and inductive loads found in applications such as motor drives, incandescent lamps, LED drivers and battery charging sources.

| Model | Constant Voltage | Max Current (CV Mode) | Output Power (Tb = +85°C) |
|----------------|------------------|-----------------------|---------------------------|
| ACS12.600IHC | 12V | 50A | 600W |
| ACS24.600IHC | 24V | 25A | 600W |
| In Development | 48V | 12.5A | 600W |

600 WATT AC-DC IHC CONVERTERS

Preliminary



Mechanicals

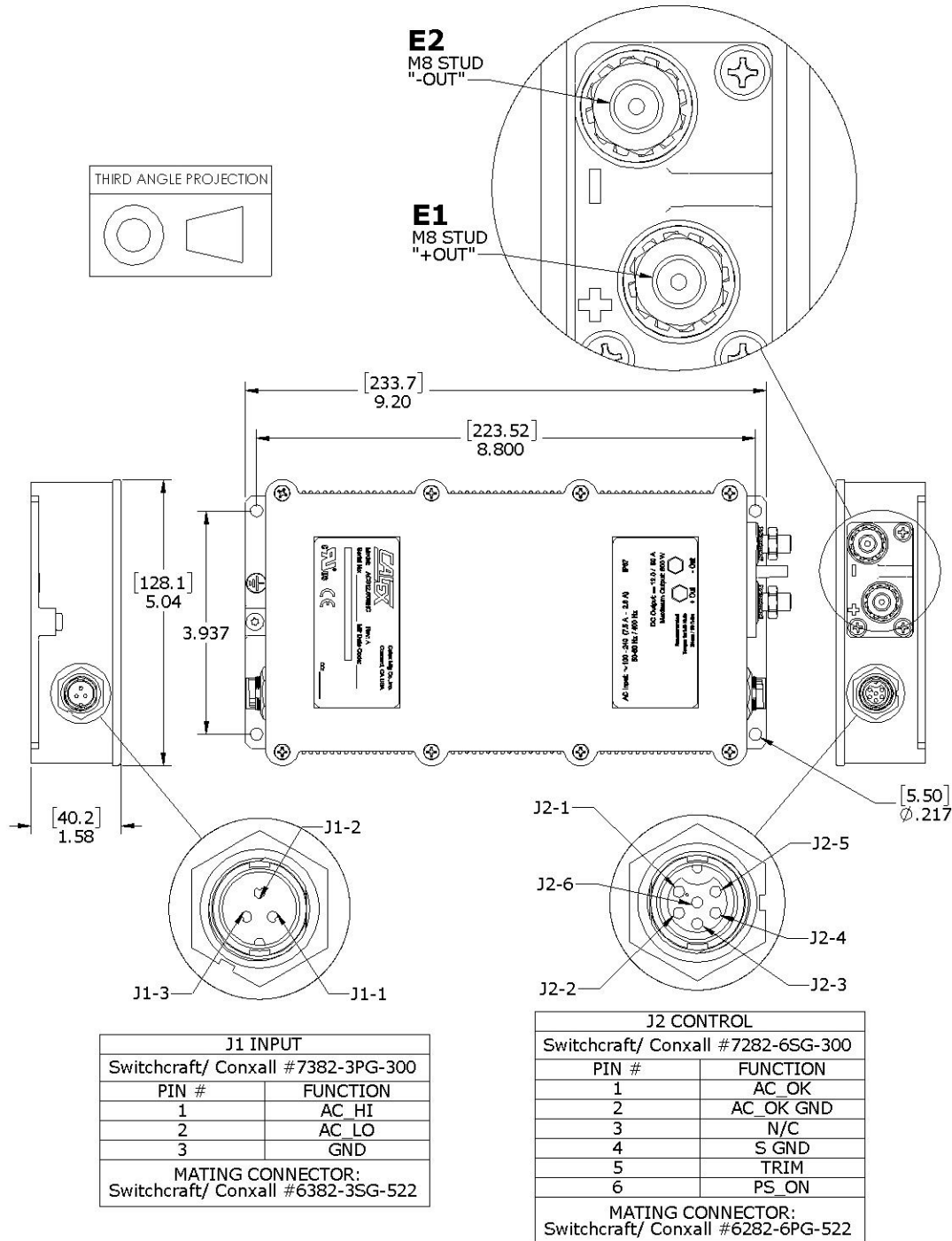

600 WATT AC-DC IHC CONVERTERS

Preliminary



| INPUT, SIGNAL AND MATING CONNECTORS | | | | |
|-------------------------------------|-----|--|--------------------------|-----------------------------|
| Connector | PIN | Description | PSU Module | Mating Connector |
| Input Connector J1 | 1 | AC_HI (Line) | Switchcraft 7382-3PG-300 | Switchcraft 6382-3SG-522 |
| | 2 | AC_LO (Neutral) | | |
| | 3 | GND/PE (Ground/Protective Earth) | | |
| Signal Connector J3 | 1 | AC_OK | Switchcraft 7282-6SG-300 | Switchcraft 6282-6PG-522 |
| | 2 | AC_OK_GND | | |
| | 3 | N/C – No User Connection | | |
| | 4 | SGND | | |
| | 5 | TRIM | | |
| | 6 | PS_ON | | |

| OUTPUT CONNECTIONS | | | | | |
|--------------------|------|-------------|---|--|-----------------|
| Connector | PIN# | Description | Recommended Cable Gauge (minimum) | Stud Terminal Thread | Connector Image |
| Studs | E1 | +DC_OUT | 6AWG/13.3mm ² | M8 X 1.25 PHOSPHOR BRONZE, TIN PLATED OUTPUT STUDS (HEX NUTS AND EXT TOOTH LOCKWASHERS SUPPLIED) | |
| | E2 | +DC_OUT | | | |