

PFE3000-360-069RA

3000 W AC-DC Front-End Power Supply

Bel Power Solutions **PFE3000-360-069RA** is a 3000 Watt ACDC power-factor-corrected (PFC) and DC-DC power supply that converts standard AC mains power or high voltage DC bus voltages into a main output of 360 VDC for powering high voltage DC Equipment.

The PFE3000-360-069RA meets international safety standards and displays the CE-Mark for the European Low Voltage Directive (LVD).

Key Features & Benefits

- Best-in-class efficiency of up to 97.5%
- Wide input voltage range: 200 VAC to 300 VAC
- AC input with power factor correction
- 3000W / 360VDC main output with 1V / A droop
- Output isolated from PE but referred to PE with +- 180 VDC
- Advanced safety protection features; detection of output voltage common mode drifts relative to PE
- Paralleling capability available upon request
- One single rear side connector for input and output power and signaling
- Small form factor: 69 x 40.6 x 528 mm
- Full digital controls for improved performance
- CAN communication interface for monitoring, control, and firmware update via bootloader
- Overtemperature, output overvoltage and overcurrent protection
- 2 Status LEDs: AC OK and DC OK with fault signaling
- Safety-approved to IEC/EN 60950-1 and UL/CSA 60950-1 2nd ed and IEC62368-1
- 1kV differential mode, 2 kV common mode surge rated on the output
- RoHS Compliant
- US Patent Pending

Applications

- High Voltage DC Distribution



bel POWER
SOLUTIONS &
PROTECTION

a bel group

belfuse.com/power-solutions

1. ORDERING INFORMATION

PFE	3000	-	360	-	069	R	A	Option Code
Product Family	Power Level	Dash	V1 Output	Dash	Width	Airflow	Input	Blank
PFE Front-Ends	3000 W		360 V		69 mm	R: Reversed ¹	A: AC	Standard model

2. OVERVIEW

The PFE3000-360-069RA is a fully DSP controlled, highly efficient front-end power supply. It incorporates resonant-soft-switching technology and highly integrated conversion stages to reduce component stresses, providing increased system reliability, very high efficiency and high power density. With a wide input operating voltage range and minimal derating of output power with respect to ambient temperature, the PFE3000-360-069RA maximizes power availability in demanding server, switch, and router applications. The power supply is fan cooled and ideally suited for server integration with a matching airflow path.

The PFC stage is digitally controlled using a state-of-the-art digital signal processing algorithm to guarantee best efficiency and unity power factor over a wide operating range when using AC input voltage. When operated with high voltage DC the PFC circuit is still in operation, but input current is controlled to be DC.

The DC-DC stage uses a soft-switching resonant power conversion topology with advanced digital control to allow operation in a wide output voltage range.

Status information is provided with front-panel LEDs. In addition, the power supply can be monitored and controlled (i.e. fan speed setpoint) via CAN communication interface. It allows full monitoring of the supply, including input and output voltage, current, power, and inside temperatures. The same CAN bus supports the bootloader to allow field update of the firmware in the DSP controllers.

Cooling is managed by a fan, controlled by the DSP controller. The fan speed is adjusted automatically depending on the actual power demand and supply temperature and can be overridden through the CAN bus.

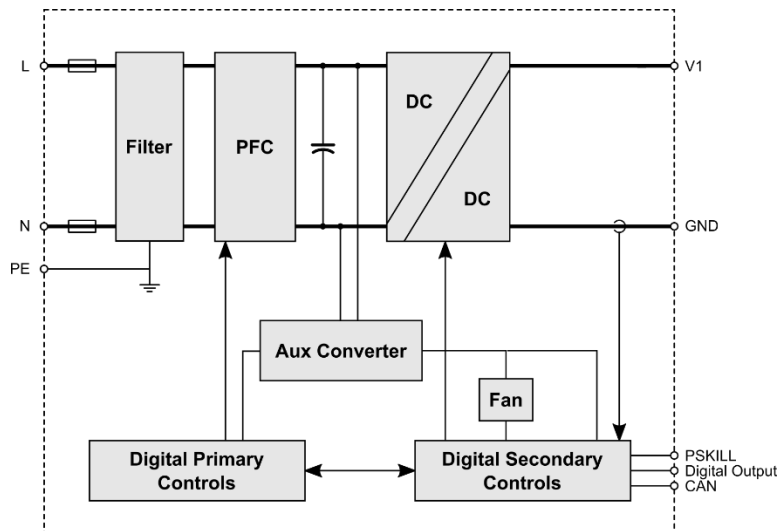

Figure 1. PFE3000-360-069RA Block Diagram

¹ Front to Rear

3. ABSOLUTE MAXIMUM RATINGS

Stresses in excess of the absolute maximum ratings may cause performance degradation, adversely affect long-term reliability, and cause permanent damage to the power supply.

PARAMETER	CONDITIONS / DESCRIPTION	MIN	MAX	UNITS
$V_{i,maxc}$	Maximum Input	Continuous	300 400	VAC VDC

4. INPUT

General Condition: $T_A = 0...45\text{ °C}$ unless otherwise specified.

PARAMETER	DESCRIPTION / CONDITION	MIN	NOM	MAX	UNIT		
$V_{i,AC,nom}$	Rated AC Input Voltage	200	230	277	VAC		
$V_{i,AC,operating}$	AC Input Voltage Range	Operating AC Input Voltage ($V_{i,AC,min}$ to $V_{i,AC,max}$)		305	VAC		
$V_{i,DC,nom}$	Rated DC Input Voltage	200		380	VDC		
$V_{i,DC,operating}$	DC Input Voltage Range	Operating DC Input Voltage ($V_{i,DC,min}$ to $V_{i,DC,max}$)		400	VDC		
$I_{i,max}$	Max Input Current	$V_{i,AC} > 200\text{ VAC}$ or $V_{i,DC} > 200\text{ VDC}$		17	A_{rms}		
$I_{i,p}$	Inrush Current Limitation	$V_{i,AC,min}$ to $V_{i,AC,max}$ or $V_{i,AC,min}$ to $V_{i,AC,max}$, $T_{NTC} = 25\text{ °C}$		50	A_p		
F_i	Input Frequency	47	50/60	63	Hz		
PF	Power Factor	$V_{i,AC,nom}$, 50Hz, $I_1 > 0.3 I_{1,nom}$		0.96	W/VA		
$V_{i,AC,on}$	Turn-on AC Input Voltage ²	Ramping up		173	176	179	VAC
$V_{i,AC,off}$	Turn-off AC Input Voltage	Ramping down		167	170	173	VAC
η	Efficiency	$V_i = 277\text{ VAC}$, $0.1 \cdot I_{1,nom}$, $I_{SB} = 0A$, $V_{x,nom}$, $T_A = 25\text{ °C}$		94.6		%	
		$V_i = 277\text{ VAC}$, $0.2 \cdot I_{1,nom}$, $I_{SB} = 0A$, $V_{x,nom}$, $T_A = 25\text{ °C}$		96.6			
		$V_i = 277\text{ VAC}$, $0.5 \cdot I_{1,nom}$, $I_{SB} = 0A$, $V_{x,nom}$, $T_A = 25\text{ °C}$		97.4			
		$V_i = 277\text{ VAC}$, $I_{1,nom}$, $I_{SB} = 0A$, $V_{x,nom}$, $T_A = 25\text{ °C}$		96.5			
T_{hold}	Hold-up Time	After last AC zero crossing, $V_1 > 310V$, $V_{i,AC,nom}$ or $V_{i,DC,nom}$, $P_{1,nom}$		TBD	ms		

4.1. INPUT FUSE

Fast-acting 30 A input fuses (6.3 × 32 mm) in series with both the L- and N-line inside the power supply protect against severe defects. The fuses are not accessible from the outside and are therefore not serviceable parts.

4.2. INRUSH CURRENT

The AC-DC power supply exhibits an X capacitance of 5.8 μF , resulting in a low and short peak current, when the supply is connected to the mains. The internal bulk capacitors will be charged through NTC resistors which will limit the inrush current.

NOTE:

Do not repeat plug-in / out operations below 30 sec interval time, or else the internal in-rush current limiting device (NTC) may not sufficiently cool down and excessive inrush current may result.

² The Front-End is provided with a minimum hysteresis of 3 V during turn-on and turn-off within the ranges

4.3. INPUT UNDER-VOLTAGE

If the input voltage (either AC or DC) stays below the input under-voltage lockout threshold $V_{iAC\ on}$ or $V_{iDC\ on}$, the supply will be inhibited. Once the input voltage returns within the normal operating range, the supply will return to normal operation again.

4.4. POWER FACTOR CORRECTION

Power factor correction (PFC) is achieved by controlling the input current waveform synchronously with the input voltage. A fully digital controller is implemented giving outstanding PFC results over a wide input voltage and load range. The input current will follow the shape of the input voltage. If, for instance, the input voltage has a trapezoidal waveform, then the current will also show a trapezoidal waveform.

4.5. EFFICIENCY

The high efficiency is achieved by using state-of-the-art silicon power devices in conjunction with soft-transition topologies minimizing switching losses and a full digital control scheme. Synchronous rectifiers on the output reduce the losses in the high current output path. The rpm of the fan is digitally controlled to keep all components at an optimal operating temperature regardless of the ambient temperature and load conditions. *Figure 2* shows the measured efficiency with AC input voltage applied, with standby output at zero load.

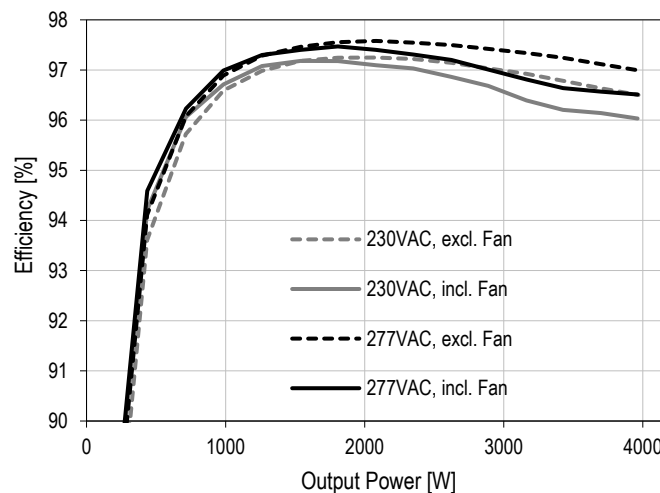

Figure 2. Typical Efficiency vs. Load Current

5. OUTPUT

General Condition: $T_A = 0 \dots 45 \text{ }^\circ\text{C}$ unless otherwise noted.

PARAMETER	DESCRIPTION / CONDITION	MIN	NOM	MAX	UNIT
<i>Main Output V1</i>					
$V_{1 \text{ nom}}$	Nominal Output Voltage	$0.5 \cdot I_{1 \text{ nom}}, T_a \leq 45^\circ\text{C}$		345	VDC
$V_{1 \text{ set}}$	Output Setpoint Accuracy	$0.5 \cdot I_{1 \text{ nom}}, T_a \leq 45^\circ\text{C}$		-0.5	+0.5 % $V_{1 \text{ nom}}$
$dV_{1 \text{ tot}}$	Total Regulation	$V_{i \text{ min}}$ to $V_{i \text{ max}}, 0$ to 100% $I_{1 \text{ nom}}, T_{a \text{ min}}$ to $T_{a \text{ max}}$		-2	+2 % $V_{1 \text{ nom}}$
$P_{1 \text{ nom}}$	Nominal Output Power			3000	W
$I_{1 \text{ nom}}$	Nominal Output Current	$V_i = V_{i \text{ AC/DC min}} \dots V_{i \text{ AC/DC max}}$		9	A
$v_{1 \text{ pp}}$	Output Ripple Voltage	20 MHz BW, measured with 100nF ceramic bypass capacitor in parallel to probe		2	Vpp
$dV_{1 \text{ Load}}$	Load Regulation	$V_i = V_{i \text{ nom}}, 0 - 100\% I_{1 \text{ nom}}$		-1	V/A
$dV_{1 \text{ Line}}$	Line Regulation	$V_i = V_{i \text{ AC/DC min}} \dots V_{i \text{ AC/DC max}}$		0	V
$P_{1 \text{ Lim}}$	Power Limitation	$V_i = V_{i \text{ AC/DC min}} \dots V_{i \text{ AC/DC max}}$		3100	W
$I_{1 \text{ Lim}}$	Current Limitation	$V_i = V_{i \text{ AC/DC min}} \dots V_{i \text{ AC/DC max}}$		9.2	A
dV_{dyn}	Dynamic Load Regulation	$\Delta I_1 = 50\% I_{1 \text{ nom}}, I_1 = 10 \dots 100\% I_{1 \text{ nom}},$ $dI_1/dt = 1\text{A}/\mu\text{s}, f = 2 \dots 50 \text{ Hz},$ Duty cycle = 20 ... 80%		-TBD	TBD V
T_{rec}	Recovery Time	Within 1% of V_1 final steady state $I_1 = 10 \dots 100\% I_{1 \text{ nom}}$		2	ms
$t_{\text{AC } V_1}$	Start-up Time from AC	Time from V_i in range to V_1 in regulation		4	sec
$dV_{V_1 \text{ rise}}$	Voltage rise slew rate	$V_1 = 10 \dots 90\% V_{1 \text{ nom}}, I_1 = 0 \dots 100\% I_{1 \text{ nom}}$		TBD	V / ms

5.1. OUTPUT ISOLATION

The main output is basic-isolated from protective earth (PE). All signals and control circuits are referred to PE, i.e. the control ground is directly connected to PE within the PSU.

The main output rails are balanced relative to protective earth such that the common mode voltage is zero. This is achieved with a high impedance resistive divider ($2 \times 2.25 \text{ MOhm}$). This allows detecting unexpected common mode shifts of the output voltage.

The PSU continually reads V_{1CM} , the common mode voltage of the output relative to PE and shuts-off if an imbalance is detected. If the $|V_{1CM}| > V_{1CM, \text{slow}}$ the PSU will turn off after $t_{1CM, \text{slow}}$, however if $|V_{1CM}| > V_{1CM, \text{fast}}$ the PSU will turn off immediately. This protection scheme detects failures in the isolation system and improves safety in case of human interaction with the high voltage bus.

Note that the standard version of PFE3000-360-069RA does not feature an ORing diode and usage in parallel is not recommended. A version with ORing diode is available upon request.

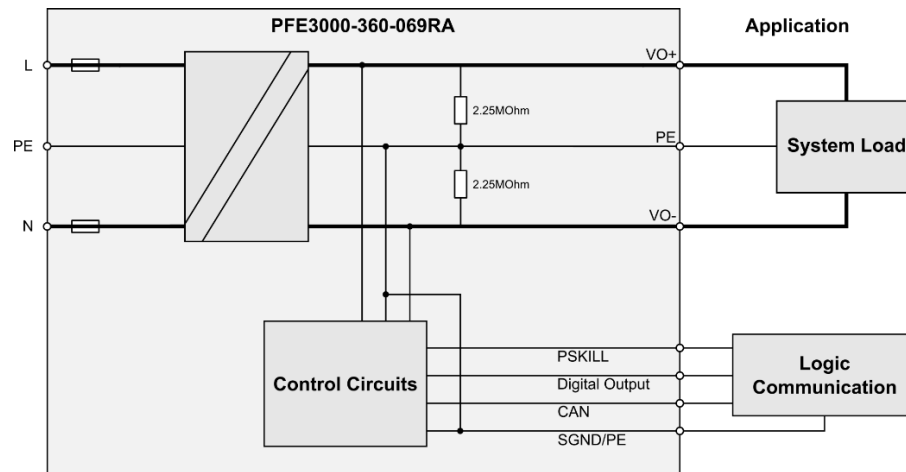

Figure 3. Connecting the system load

6. PROTECTION

PARAMETER	DESCRIPTION / CONDITION	MIN	NOM	MAX	UNIT	
F	Input Fuses (L+N)	Not user accessible, fast-acting (F)			30	A
V _{1 OV}	OV Threshold V ₁	410	420	430	VDC	
t _{1 OV}	OV Latch Off Time V ₁				1	ms
P _{1 lim}	Nominal Power Limitation	V _{1 AC/DC HL}	3100	3250	3400	W
I _{1 lim}	Nominal Current Limitation	V _{1 AC/DC HL}	9.2	9.5	9.8	A
I _{1 SC}	Max Short Circuit Current V ₁	V ₁ < 10 VDC, excluding output capacitor discharging current			9.8	ADC
t _{1 SC off}	Short circuit latch off time	Time to latch off when in short circuit or output under voltage (V ₁ < V _{1 UV})			20	ms
V _{1 UV}	Output under voltage protection	305	310	315	VDC	
t _{1 UV}	Output under voltage protection delay time	V ₁ < V _{1 UV}			20	ms
T _{SD}	Over temperature on critical points	Inlet Ambient Temperature PFC Primary Heatsink Temperature Secondary Sync Diode Temperature Secondary OR-ing Mosfet Temperature			TDB	°C
V _{1CM, slow}	Common mode voltage shift level to trigger slow common mode fault				50	V
V _{1CM, fast}	Common mode voltage shift level to trigger fast common mode fault				100	V
t _{1CM, slow}	Time to trigger common mode fault if V _{1CM, fast} > V _{1CM} > V _{1CM, slow}				20	ms

6.1. AUTOMATIC RETRY

For all faults except for overtemperature faults, the main output will shut off and attempt to restart after 10s. Overtemperature protection is implemented using a hysteresis and the PSU resumes operation if the internal temperatures have reduced 10°C below the critical temperatures.

6.2. UNDER VOLTAGE DETECTION

The LED and PWOK_L pins signal if the output voltage deviates ±10 V of its nominal voltage. When the main output falls below V_{1 UV} the output is inhibited and enters the automatic retry sequence as described under 6.7.

6.3. CURRENT LIMITATION MAIN OUTPUT

The PSU features a substantially rectangular output characteristic controlled by a software feedback loop. If the output current reaches I_{1 lim}, the supply will immediately reduce its output voltage to prevent the output current from exceeding I_{1 lim}. When the output current is reduced below I_{1 lim}, the output voltage will return to its nominal value. See also **Error! Reference source not found.** for output characteristic and current limitation at different output voltage settings.

7. MONITORING

The power supply provides information about operating conditions through its CAN bus interface. Details can be found in the CAN Communication Manual BCA.00231.0. Accuracy of sensors within PSU is given in following table.

PARAMETER	DESCRIPTION / CONDITION	MIN	NOM	MAX	UNIT	
$V_{i \text{ mon}}$	Input RMS Voltage	$V_{i \text{ min}} \leq V_i \leq V_{i \text{ max}}$		-2	+2	%
$I_{i \text{ mon}}$	Input RMS Current	$I_i > 5 A_{\text{rms}}$		-5	+5	%
		$I_i \leq 5 A_{\text{rms}}$		-0.25	+0.25	A_{rms}
$P_{i \text{ mon}}$	True Input Power	$P_i > 800 \text{ W}$		-5	+5	%
		$P_i \leq 800 \text{ W}$		-40	+40	W
$V_{1 \text{ mon}}$	V_1 Voltage	$V_1 > 300 \text{ VDC}$		-1	+1	%
$I_{1 \text{ mon}}$	V_1 Current	$I_1 \leq I_{1 \text{ nom}}$		-0.1	+0.1	A
$P_{1 \text{ mon}}$	Total Output Power	$P_1 > 1000 \text{ W}$		-3	+3	%
		$P_1 \leq 1000 \text{ W}$		-30	+30	W
$T_{a \text{ mon}}$	Inlet air temperature	$T_a = 0 \dots 45^\circ\text{C}$		-2	+2	$^\circ\text{C}$

8. SIGNALING AND CONTROL

8.1. ELECTRICAL CHARACTERISTICS

PARAMETER	DESCRIPTION / CONDITION	MIN	NOM	MAX	UNIT
PSKILL					
V _{IL}	Input low level voltage (Main output enabled)	-0.2		0.8	V
V _{IH}	Input high level voltage (Main output disabled)	2.0		3.5	V
I _{IL, H}	Maximum input sink or source current	0		1	mA
R _{puPSKILL}	Internal pull up resistor on PSKILL to internal 3.3V		4.75		kΩ
DIGITAL OUTPUT					
V _{OL}	Output low level voltage	<i>I_{sink} < 4 mA</i>	-0.2	0.4	V
V _{puPWOK_L}	External pull up voltage	0		13	V
R _{puPWOK_L}	Recommended external pull up resistor on PWOK_L at V _{puPWOK_L} = 3.3 V		10		kΩ
Low level output	Configurable, details to be defined				
High level output	Configurable, details to be defined				

8.2. PSKILL INPUT

The PSKILL input is an active-high and trailing pin in the connector and is used to disconnect the main output as soon as the power supply is being plugged out. The PSU features an active discharge circuit which discharges the output within a few seconds in case it is plugged out.

This can be connected to SGND, enabling main output as soon as power supply is plugged-in into system with input voltage present. Alternatively, this input can be driven by a logical signal (preferably an open collector signal) from the application, allowing remote control of the main output.

8.3. PWOK_L OUTPUT

The PWOK_L output is an open collector output which is asserted if the output voltage deviates by more than ±10 V of its nominal voltage.

8.4. CAN BUS INTERFACE

The CAN bus interface serves for with a system controller e.g. voltage setting, monitoring. The CAN bus operates at 1000 kbit/s with a Bel defined protocol. System wiring requires only interconnection of CAN_H and CAN_L lines, in addition a 120 Ohm termination resistor is required at each end of the CAN bus.

8.5. FRONT LEDs

The front-end has 2 front LEDs showing the status of the supply. LED number one is green and indicates AC power is on or off, while LED number two is bi-colored: green and yellow, and indicates DC power presence or fault situations. If the PSU bootload is in progress both LEDs are alternating green blinking. All other conditions are specified in the *Table 1*. The order of the criteria in the table corresponds to the testing precedence in the controller. LEDs are only available if sufficient input voltage is applied for operation of the internal supply circuits.

OPERATING CONDITION	LED SIGNALING
Bootload in progress	LEDs alternately blinking
AC LED	
AC Line within range	Solid Green
AC Line out of range	Off
DC LED	
V ₁ out of regulation	Solid Yellow
Over temperature shutdown	
Output over voltage shutdown	
Output under voltage shutdown	
Output over current shutdown	Blinking Green
Power Supply Turned Off	
Normal Operation	Solid Green
PSU back supplied and input voltage present but out of range	Blinking Yellow
Otherwise	All LEDs off

Table 1. LED Status

9. TEMPERATURE AND FAN CONTROL

To achieve best cooling results sufficient airflow through the supply must be ensured. Do not block or obstruct the airflow at the rear of the supply by placing large objects directly at the output connector. The PFE3000-360-069RA is provided with a reverse airflow, which means the air enters through the front of the supply and leaves at the rear. TET supplies have been designed for horizontal operation.

9.1. FAN CONTROL

The average speed of the two individual fans within the dual-axis-fan is controlled to meet the reference. The reference is given by the maximum of following 3 items:

- Load depending Fan Speed curve, see *Figure 4*. This curve is in use at nominal conditions.
- Component depending Fan Speed curve according to *Figure 5*.
- System commanded Fan Speed through CAN bus.

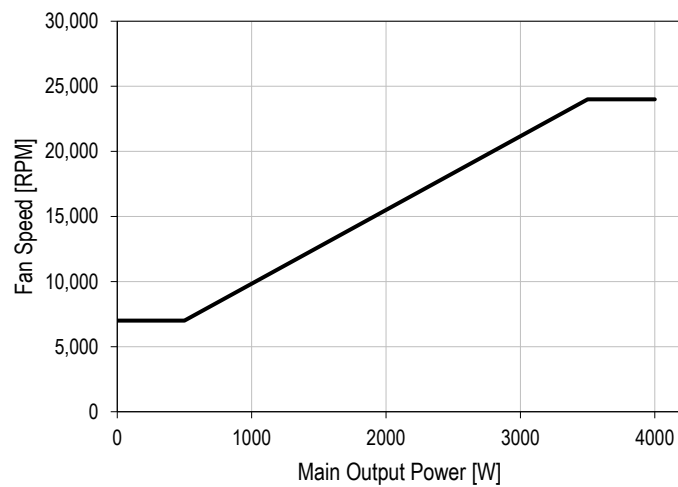

Figure 4. Fan speed versus main output power

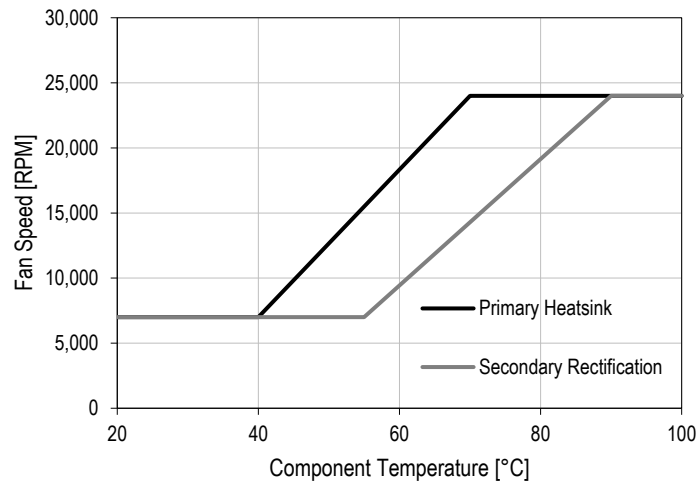

Figure 5. Fan speed versus power stage temperatures

10. ELECTROMAGNETIC COMPATIBILITY

10.1. IMMUNITY

NOTE: Most of the immunity requirements are derived from EN 55024:1998/A2:2003.

PARAMETER	DESCRIPTION / CONDITION	CRITERION
ESD Contact Discharge	IEC / EN 61000-4-2, ± 8 kV, 25+25 discharges per test point (metallic case, LEDs, connector body)	A
ESD Air Discharge	IEC / EN 61000-4-2, ± 15 kV, 25+25 discharges per test point (non-metallic user accessible surfaces)	A
Radiated Electromagnetic Field	IEC / EN 61000-4-3, 10 V/m, 1 kHz/80% Amplitude Modulation, 1 μ s Pulse Modulation, 10 kHz...2 GHz	A
Burst	IEC / EN 61000-4-4, level 3 AC port ± 2 kV, 1 minute	A
Surge	IEC / EN 61000-4-5, level 3 Line to earth: ± 2 kV @ 20 Ω Line to line: ± 2 kV @ 20 Ω	A
RF Conducted Immunity	IEC/EN 61000-4-6, Level 3, 10 Vrms, CW, 0.1 ... 80 MHz	A
Voltage Dips and Interruptions	IEC/EN 61000-4-11	
	1: V_i 230 Volts, 100% Load, Dip 100%, Duration 12 ms 2: V_i 230 Volts, 100% Load, Dip 100%, Duration > 12 ms	A B

10.2. EMISSION

PARAMETER	DESCRIPTION / CONDITION	CRITERION
Conducted Emission	EN55022 / CISPR 22: 0.15 ... 30 MHz, QP and AVG	Class A + 6 dB margin
Radiated Emission	EN55022 / CISPR 22: 30 MHz ... 1 GHz, QP	Class A + 6 dB margin
Harmonic Emissions	IEC61000-3-12, $V_{in} = 230$ VAC, 50 Hz, 100% Load	Class A
Audible Noise LpA	V_{nom} , 50% I_{nom} , $T_A = 25^\circ\text{C}$, at the bystander position	60 dBA
AC Flicker	IEC / EN 61000-3-3, $d_{max} < 3.3\%$	PASS

11. SAFETY / APPROVALS

Maximum electric strength testing is performed in the factory according to IEC/EN 60950, and UL 60950. Input-to-output electric strength tests should not be repeated in the field. Bel Power Solutions will not honor any warranty claims resulting from electric strength field tests.

PARAMETER	DESCRIPTION / CONDITION	MIN	NOM	MAX	UNIT
Agency Approvals	Approved to the latest edition of the following standards: UL/CSA 60950-1, IEC60950-1, EN60950-1, IEC62368-1				
Isolation Strength	Input (L/N) to case (PE)			Basic	
	Input (L/N) to output Output to case (PE)			Reinforced Functional	
α Creepage / Clearance	Primary (L/N) to protective earth (PE) Primary to secondary				
Electrical Strength Test	Input to case	2121			VDC
	Input to output (tested by manufacturer only)	4242			

12. ENVIRONMENTAL

PARAMETER	DESCRIPTION / CONDITION	MIN	NOM	MAX	UNIT
T_A Ambient Temperature	V_{min} to V_{max} , I_{nom} , at 4000 m	0		+35	$^\circ\text{C}$
	V_{min} to V_{max} , I_{nom} , at 1800 m	0		+55	$^\circ\text{C}$
T_S Storage Temperature	Non-operational	-40		+70	$^\circ\text{C}$
Altitude	Operational, above Sea Level (see derating)	-		4000	m
Cooling	System Back Pressure			0.5	in-H ₂ O

13. MECHANICAL

PARAMETER	DESCRIPTION / CONDITION	MIN	NOM	MAX	UNIT
Dimensions	Width		69		mm
	Height		40.5		mm
	Depth		530		mm
<i>m</i> Weight			2.7		kg

NOTE: A 3D step file of the power supply casing is available on request.

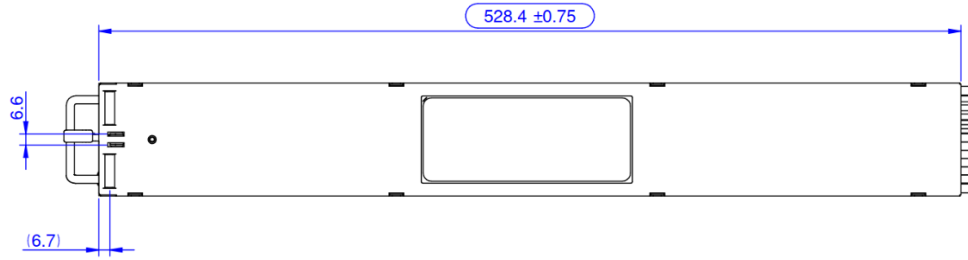

Figure 6. Top view

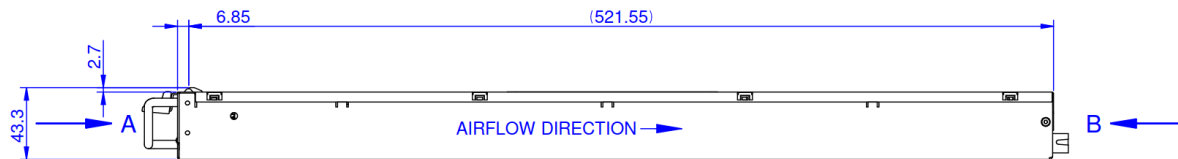

Figure 7. Side view

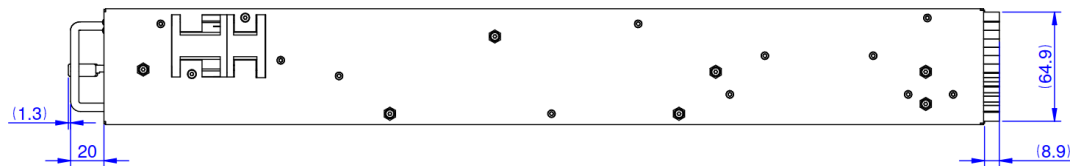

Figure 8. Bottom view

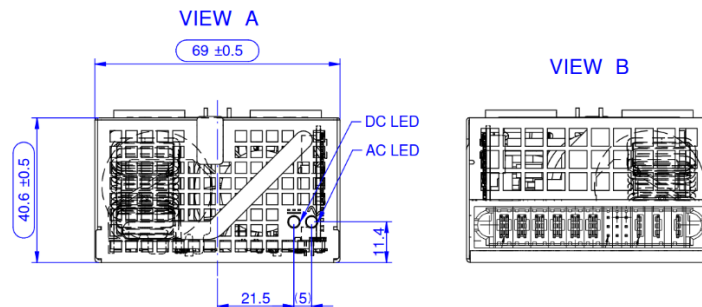

Figure 9. Front and Rear view

14. CONNECTOR

Rear side PSU connector serves as interface for input power (AC or HV DC), output power and signals. In order to guarantee proper mating sequence, the below noted connector P/N is required to be used.

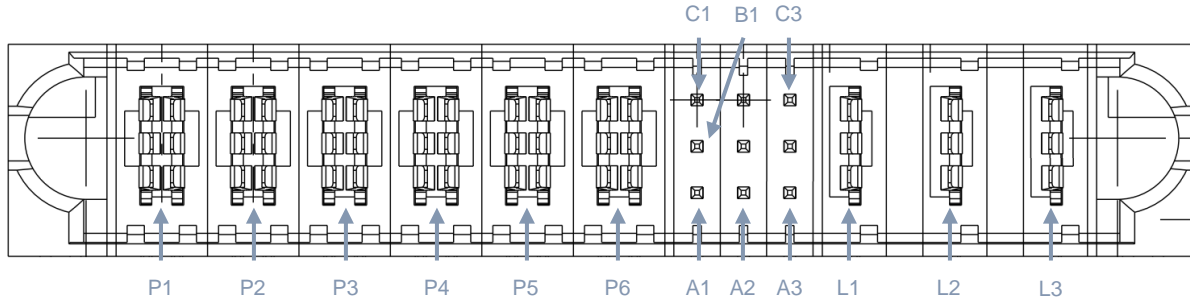



Figure 10. PSU rear side connector, view from mating side

VERSION	TYPE	MANUFACTURER	BEL P/N	MANUFACTURER P/N
PSU Connector	PWRBLADE ULTRA®	Amphenol FCI	-	10127397-07H1420LF
System Connector	PWRBLADE ULTRA®	Amphenol FCI	ZES.01164 ZES.01224	10127401-08H1420LF (Solder version) 10127400-01H1420LF (Press-Fit version)

PIN	SIGNAL NAME	DESCRIPTION	MATING SEQUENCE
L1	PE	Protective Earth	1
L2	N	AC or HV DC input line (Neutral)	2
L3	L	AC or HV DC input line (Line)	2
P3	VO+	Positive output rail	2
P1	VO-	Negative output rail	2
P6	NC	Not Connected	2
P2, P4, P5	NC	Pins Removed from Connector	N.A.
A1	PSKILL	Power supply kill (lagging pin); active-high	3
B1	PWOK_L	Power OK open collector output	2
C1	PE/SGND	Protective Earth as well as signal ground	2
A2	RSVD1	Reserved. Leave open.	2
B2	CAN_H	CAN-Interface, High	2
C2	CAN_L	CAN-Interface, Low	2
A3	RSVD2	Reserved. Leave open.	2
B3	12Vaux	100mA fused (polyfuse)	2
C3	PE/SGND	Protective Earth as well as signal ground	2

Table 2. Pin assignment

15. ACCESSORIES

ITEM	DESCRIPTION	ORDERING PN	SOURCE
	Interface Utility Windows compatible GUI to program, control and monitor Bel products	N/A	belfuse.com/power-solutions

16. REVISION HISTORY

REV	DESCRIPTION	PSU PRODUCT VERSION	DATE	AUTHOR
001	Initial Draft.	V001	2018-07-17	RB

For more information on these products consult: tech.support@psbel.com

NUCLEAR AND MEDICAL APPLICATIONS - Products are not designed or intended for use as critical components in life support systems, equipment used in hazardous environments, or nuclear control systems.

TECHNICAL REVISIONS - The appearance of products, including safety agency certifications pictured on labels, may change depending on the date manufactured. Specifications are subject to change without notice.



Asia-Pacific	Europe, Middle East	North America
+86 755 298 85888	+353 61 225 977	+1 408 785 5200